

## VersaTEK Large LED Floodlight Series VTLFL Specification Data Sheet

### Luminaire Data

- Weight** 33.7 lbs [15.3 kg] ('SF', 'SFH', 'SFC' mount)  
 35.9 lbs [16.3 kg] ('TR' mount)  
 33.3 lbs [15.1 kg] ('YK' mount)  
 37.5 lbs [17.0 kg] ('AWM' mount)  
 41.0 lbs [18.6 kg] ('AWMSC' mount)  
 33.1 lbs [15.0 kg] ('ASPM' mount)  
 33.7 lbs [15.3 kg] ('ARPM' mount)



(\*VTLFL large housing w/ 'SF' slipfitter mount & optional 'PCR7CR' shown)

### Ordering Information

Sample Catalog No. VTLFL-216A-MV-40K7-N66-DB1-CF-P7-SFH-PCR7CR-NB01P-TB-WL1-SP2-SF120

Product	LED Code	Voltage	Color Temp CRI	Optical Distribution	Finish*	Performance Code	Mounting Options
VTLFL VersaTEK Large Flood	216A 216 LEDs Gen-A	MV 120-277V HV 347-480V	27K7 2700K, 70CRI 30K7 3000K, 70CRI 40K7 4000K, 70CRI 50K7 5000K, 70CRI  30K8 <sup>1</sup> 3000K, 80CRI 40K8 <sup>1</sup> 4000K, 80CRI 50K8 <sup>1</sup> 5000K, 80CRI	N66 NEMA 6Hx6V Flood S33 NEMA 3Hx3V Spot  NSP Narrow Spot RN Rectangular Narrow RM Rectangular Medium RW Rectangular Wide WG Wall Grazer	BK Black DB1 Dark Bronze (RAL8019) WH White GY Gray  CF Coastal Finish  *Consult factory for custom finish options, pricing & leadtimes.	P1 P2 P3 P4 P5 P6 P7  (see Page 3 for details)	SF <sup>2</sup> Slipfitter w/ Wire Leads (in UL splice compartment) SFH <sup>3</sup> Slipfitter w/ S/O Cord Exiting Housing Bottom (3-wire S/O cord, 16AWG, 4' exit length) SFC <sup>3</sup> Slipfitter w/ S/O Cord Exiting Center of Fitter (3-wire S/O cord, 16AWG, 4' exit length) TR <sup>3</sup> Trunnion Mount (3-wire S/O cord, 16AWG, 4' exit length) YK <sup>3</sup> Yoke Mount (3-wire S/O cord, 16AWG, 4' exit length) AWM Adjustable Wall Mount (compatible w/ 3" & 4" square/octagonal recessed J-boxes) AWMSC Adjustable Wall Mount w/ Surface Conduit J-Box ASPM Universal Square Pole Adjustable Arm Mount ARPM Universal Round Pole Adjustable Arm Mount

Driver* & Control Options (*0-10V drivers are standard)	General Options
D41 <sup>4,7</sup> DALI D4i Driver TLR4U <sup>4,5,8</sup> DALI 4-PIN Twist Lock Receptacle (upper housing receptacle location) TLR4L <sup>4,5,8</sup> DALI 4-PIN Twist Lock Receptacle (lower driver door receptacle location)  NB01P <sup>6</sup> LEOlink 7-PIN Smart Controller (120-277V) PCR7CR <sup>4,6</sup> ANSI 7-wire Control Ready Receptacle SC Shorting Cap (factory installed) LLPC <sup>7</sup> Long Life Photocontrol  PS <sup>8</sup> Field Adjustable Performance Selector PND1 <sup>9</sup> Part Night Dimming V1 PND2 <sup>9</sup> Part Night Dimming V2 PND3 <sup>9</sup> Part Night Dimming V3	AIM45 <sup>10</sup> Slipfitter Factory Pre-aimed at 45° SS Slipfitter Set Screw (replaces standard slipfitter set bolts) TFL Tamper free latch (driver electrical door) TB <sup>2</sup> 3-position Terminal Block SP2 <sup>11</sup> 20kV/10kA Extreme Surge, Fail-to-On LSSP2 20kV/10kA Extreme Surge, Fail-to-Off WL Wattage Label, ANSI C136.15-2015 compliant WL1 Wattage Label, ANSI C136.15-2020 compliant DSC Optional Driver Door Safety Cable PWRD Power Door Option (tool-free removable door w/ serviceable electrical items) SFXXX <sup>12</sup> Single Fuse ('XXX' = specify voltage 120, 277, 347V) DFXXX <sup>12</sup> Double Fuse ('XXX' = specify voltage 208, 240, 480V) 5WSO <sup>13</sup> 5-wire S/O Cord (16AWG, 4' length w/ dimming leads) SOXXYY <sup>14</sup> Special S/O AWG & Cord Length in Feet ('XX' = specify AWG 12, 14 or 16) ('YY' = specify S/O cord length 06, 08, 10, 15, 25)

General Accessories*
<p><b>Shield Accessories</b></p> <p>TBS-VTL Top, Bottom Shield LRS-VTL Left, Right Side Shield 4SS-VTL 4-sided Shield BDS-VTL Barn Door Shield VS-VTL Poly Vandal Shield WG-VTL Wire Guard BSK Bird Deterrent Spider Kit</p> <p><b>Controls Accessories</b></p> <p>NB01PSS<sup>15</sup> NB01P Ships Separately LLPCMIV Long Life Photocontrol MV LLPCHV Long Life Photocontrol HV</p> <p>*Accessories are ordered &amp; shipped separately, not to be included in the luminaire's catalog number. (requires field installation)</p>

- 80CRI option only available in 3000K, 4000K & 5000K CCTs and may have longer leadtimes (contact factory).
- 'TB' Terminal Block is not available for use with the 'SF' Slipfitter mounting option. 3. Mounting option includes 16AWG 3-wire S/O cord w/ a 4' exit length & last 6" of insulation removed.
- For full 100% D4i DALI functionality a 'PCR7CR', 'TLR4U' or 'TLR4L' must be selected w/ 'D4I' DALI driver option. DALI compatible node or sensor (by others).
- 'TLR4U' & 'TLR4L' twist lock receptacle option requires 'D4I' DALI driver option to be selected.
- 'NB01P' requires 'PCR7CR' option, only available in 'MV' 120-277V (contact factory for 'HV' 347-480V availability). 'NB01P' is a cellular based NEMA 7-PIN Smart Controller, 10-YR data (200MB), RenAI subscription included.
- 'LLPC' requires 'PCR7CR' option to be selected (does not ship installed, ships included w/ luminaire).
- 'PS' Performance Selector enables field adjustable light output dimming control from specified Performance Code, not compatible with DALI driver option (see pg.5 for details).
- 'PND' options only available w/ 'MV' 120-277V (contact factory for 'HV' 347-480V availability). 10. Slipfitter options 'SF', 'SFC', 'SFH' ship pre-aimed at 45° from the factory if 'AIM45' is specified.
- 10kV/5kA surge, fail-to-on is included standard ('SP1'). 12. For single or double fusing, 'XXX' must specify required voltage.
- '5WSO' only available with 'SFC', 'SFH', 'TR' & 'YK' mounting options. Not available w/ 'PCR7CR', 'PS', 'PND', 'D4I', 'TLR4U', 'TLR4L' options.
- 'SOXXYY' option, 'XX' & 'YY' must specify S/O cord AWG & length (only available w/ SO cord mounting options).
- Denotes 'NB01P' Smart Controllers will ship bulk or master pack and ships separately from the luminaire.



### Luminaire Specifications

#### Housing & Construction

Rugged grade A360 die-cast aluminum housing, glass lens frame and door frame (<0.6% copper). Housing includes integral heatsink fins and (3) pass-thru convective cooling slots between the LED array heatsink and driver compartment for enhanced cooling and maximum thermal management to maximize LED platform and electrical component lifetime. Electrical access door provides access to electrical components via two corrosion resistant stainless-steel tool-free latches (tamper free latch option 'TFL' is available). Door can be removed without the use of tools. Electrical door comes standard with an integral VersaKICK 'kickstand' to quickly and easily prop open the door to allow for frustration free installation or maintenance. Optional 'PWRD' Power Door mounts all serviceable electrical components on the door with tool-free removal for easy field maintenance or replacement. Internal bubble level standard for leveling during install. All exposed hardware and fasteners are corrosion resistant stainless-steel. Entire luminaire is IP66 rated.

#### Flood & Wall Mounting Options

Trunnion 'TR' and yoke 'YK' mounting options are constructed of formed steel. (3) adjustable slipfitter mounting options 'SF', 'SFC' and 'SFH' are rugged A360 die-cast aluminum and includes safety thru-bolt detail if required. Slipfitter 'AIM45' options ships factory preset to a tilt of 45°. Self-centering design feature also assists with leveling during installation. Designed to install to 1-5/8", 2-3/8" and 3" O.D. tenons (by others). Available in (3) wiring configurations ('SF' includes available wire leads accessed via an integral UL recognized splice compartment, 'SFC' and 'SFH' options include S/O cord exiting the center of the slipfitter or housing bottom). Standard S/O cord configurations ('TR', 'YK', 'SFH', 'SFC') are 16AWG 3-wire with an exit length of 4' and last 6" of weatherproof covering removed. Additional wire gauges and lengths available (see 'Ordering Information' for details). Adjustable wall mount 'AWM' options mount to recessed 3" and 4" square or octagonal recessed J-boxes (by others). Surface conduit wall mount option 'AWMSC' includes (4) 3/4" NPT thru-wire taps with plugs. All wall mount options include an integral bubble level for ease of installation. Universal/retrofit adjustable square 'ASPM', adjustable round 'ARPM' arm mount options can accept bolt spacings from 2.29" to 5.25" and are designed for quick and easy single person installation. Mounting provisions meet 3G vibration per ANSI C136.31-2010 Normal Application, Bridge & Overpass.

### Color Specifications

Order Code	Color	RAL #	Pantone Equivalent
GY	Gray	7040	429C
BK	Black	9004	BLACK 6C
DB1	Dark Bronze	8019	412
WH	White	9003	11-0601

#### Light Emitting Diodes

Hi-flux/Hi-power white 5050 LED optics produce a minimum of 90% of initial lumen output at 95,000 hours of life (at 25°C) and 3535 LED optics at 118,000 hours of life based on IES TM-21. LEDs are tested in accordance with IES LM-80 testing procedures. IES TM-21 lumen maintenance life projection is based on 6X the duration of the LED's IES LM-80 performance data (estimates beyond 6X are extrapolated per TM-21). LED correlated color temperature options of 2700K, 3000K, 4000K, or 5000K @ 70CRI or 80CRI (2700K is 70CRI only). LEDs are 100% mercury and lead free.

#### Optical Systems

All Micro-lens optical systems are fully sealed to maintain an IP66 rating. All-purpose 5050 LED flood optics include a NEMA 6x6 Wide Flood 'N66' and NEMA 3x3 Spot 'S33'. Performance 3535 LED flood optics include a Narrow Spot 'NSP', Rectangular Narrow 'RN', Rectangular Medium 'RM', Rectangular Wide 'RW', Wall Grazer 'WG'. Please refer to 'Performance Data' on pages 3-4 for specific beam & optical performance details. An IK10 impact resistant glass lens is standard for ease of routine cleaning and improved light loss dirt depreciation over the life of the luminaire. Multiple glare and light trespass shielding options and accessories are available (see 'Ordering Information' for details).

#### Photometry

Luminaires photometrics are tested by certified independent testing laboratories in accordance with IES LM-79 testing procedures.

#### Electrical

Rated life of electrical components is 100,000 hours. Standard 0-10V dimmable drivers use an isolated power supply with 6kV integral surge standard. Power supply features a minimum power factor of 0.90 and <20% Total Harmonic Distortion (THD). EMC meets or exceeds FCC CFR Part 15. Optional DALI D4i certified LED drivers also available, which complies with IEC 62386 and ANSI C137.4 and DiiA. Optional 3-position terminal block accommodates 6 to 16AWG wire. Standard surge protection (10kV/5kA Surge, Fail-to-On) complies with IEEE/ANSI C62.41 and ANSI C136.2-2015. Optional 'SP2' and 'LSSP2' provides (20kV/10kA) extreme level surge protection.

#### Field Adjustability

Optional Performance Selector 'PS' is an integral 8-step fixed position dial allowing field adjustable lumen and wattage dimming control for added project and design versatility to meet installation specific requirements. The specified Performance Code provides maximum lumen output. Only compatible VersaTEK's standard 0-10V drivers. Not compatible with DALI driver option.

#### General Control Options

ANSI C136.41 7-wire controls ready photocontrol receptacle 'PCR7CR' option available for use with LEOLink nodes or by others. Receptacle has a tool-less rotatable base with a positive lock to not allow over-rotation and possible damage to the receptacle. Optional DALI D4i and Part Night Dimming driver configurations are also available for added controllability and design flexibility. DALI compatible 'TLR4U' and 'TLR4L' 4-PIN twist lock receptacle options available (wireless DALI nodes or DALI sensors are by others).

#### LEOLink Intelligent Lighting System

ANSI C136.41 7-wire smart wireless controllers allow real-time monitoring and asset management of luminaires with 'NB01P' wireless control nodes installed. RenAI cloud-based application receives system data while applying specific AI models for fault isolation and the resolution of voltage health, outages, knockdowns, energy usage, LED faults and more. Allows for full remote management of deployed install base, including the ability to store and execute customer specific schedules and performance parameters. System communicates via standard 4G/5G IoT networks with a cellular data plan and RenAI subscription.

#### Finish

Housing receives a fade and abrasion resistant textured polyester powder coat finish with 3.0 mil nominal thickness. Finish tested to withstand 5000 hours in salt spray exposure per ASTM B117 and Coastal Finish per ASTM G85. Finish tested 500 hours in UV exposure per ASTM G154 and meets ASTM D523 gloss retention.

#### Listings/Ratings/Labels

Luminaires are UL listed for use in wet locations in the United States and Canada and are rated IP66. Luminaires are qualified to operate at ambient temperatures of -40°C to 50°C. (-40°F to 122°F)

#### Government Procurement Compliance

BAA - Buy America(n) Act: All LEOTEK luminaires qualify as a "Domestic End Product" per the Buy American Act as governed by FAR.

BABA - Build America Buy America: All LEOTEK luminaires are compliant with the requirements for BABA as outlined per the Federal Highway Administration (FHWA).

#### Quality Control

Every luminaire is assembled in the USA and is performance tested before and after a 2-hour burn-in period.

#### Warranty

10-year limited warranty is standard on luminaire and components. See LEOTEK.com for warranty details, terms and conditions.

#### Standards

Luminaire complies with:  
ANSI: C136.2, C136.3, C136.10, C136.13, C136.15, C136.22, C136.31, C136.35, C136.37, C136.41, C62.41, C78.377, C82.77  
Other: FCC 47 CFR, IEC 60598, ROHS II, UL 1449, UL 1598

**Performance Data\*** (5050LED All-purpose Flood Optics, 70CRI\*, 25°C ambient... \*for 80CRI option use a 0.91 multiplier)

Normal tolerance +/- 10% due to factors that include distribution type, LED bin variance and ambient temperatures.

Perf. Code	System Wattage (W)	Optic	Beam Angle		Field Angle		27K7 (2700K CCT, 70CRI)			30K7 (3000K CCT, 70CRI)			40K7 (4000K CCT, 70CRI)			50K7 (5000K CCT, 70CRI)			LLD @ 25°C		
			°H (50%)	°V (50%)	°H (10%)	°V (10%)	Lumens	LPW	Max CD	Lumens	LPW	Max CD	Lumens	LPW	Max CD	Lumens	LPW	Max CD	50K Hours	75K Hours	100K Hours
P1	180	N66	87.9	100.2	106.9	119.6	28,970	161.0	12,198	30,829	171.0	12,980	32,293	179.0	13,597	32,293	179.0	13,597	0.979	0.972	0.965
		S33	24.9	25.2	39.5	40.1	26,292	146.0	86,414	28,136	156.0	92,477	29,473	164.0	96,869	29,473	164.0	96,869			
P2	211	N66	87.9	100.2	106.9	119.6	32,389	154.0	13,637	34,399	163.0	14,484	36,104	171.0	15,202	36,104	171.0	15,202	0.979	0.972	0.965
		S33	24.9	25.2	39.5	40.1	29,680	141.0	97,551	31,395	149.0	103,188	32,951	156.0	108,302	32,951	156.0	108,302			
P3	263	N66	87.9	100.2	106.9	119.6	39,756	151.0	16,739	42,336	161.0	17,825	44,316	169.0	18,659	44,316	169.0	18,659	0.979	0.972	0.965
		S33	24.9	25.2	39.5	40.1	36,219	138.0	119,043	38,639	147.0	126,996	40,446	154.0	132,936	40,446	154.0	132,936			
P4	290	N66	87.9	100.2	106.9	119.6	43,396	150.0	18,272	46,185	159.0	19,446	48,374	167.0	20,368	48,374	167.0	20,368	0.942	0.919	0.896
		S33	24.9	25.2	39.5	40.1	39,307	136.0	129,194	42,152	145.0	138,543	44,149	152.0	145,108	44,149	152.0	145,108			
P5	317	N66	87.9	100.2	106.9	119.6	46,958	148.0	19,771	49,985	158.0	21,046	52,344	165.0	22,039	52,344	165.0	22,039	0.942	0.919	0.896
		S33	24.9	25.2	39.5	40.1	42,713	135.0	140,387	45,619	144.0	149,939	47,773	151.0	157,018	47,773	151.0	157,018			
P6	345	N66	87.9	100.2	106.9	119.6	50,420	146.0	21,229	53,683	156.0	22,603	56,204	163.0	23,664	56,204	163.0	23,664	0.942	0.919	0.896
		S33	24.9	25.2	39.5	40.1	45,861	133.0	150,734	48,994	142.0	161,032	51,295	149.0	168,594	51,295	149.0	168,594			
P7	373	N66	87.9	100.2	106.9	119.6	53,792	144.0	22,649	57,244	153.0	24,102	59,962	161.0	25,247	59,962	161.0	25,247	0.942	0.919	0.896
		S33	24.9	25.2	39.5	40.1	49,103	132.0	161,389	52,244	140.0	171,715	54,726	147.0	179,870	54,726	147.0	179,870			

**Performance Data\*** (3535LED Performance Flood Optics, 70CRI\*, 25°C ambient... \*for 80CRI option use a 0.91 multiplier)

Normal tolerance +/- 10% due to factors that include distribution type, LED bin variance and ambient temperatures.

Perf. Code	System Wattage (W)	Optic	Beam Angle		Field Angle		27K7 (2700K CCT, 70CRI)			30K7 (3000K CCT, 70CRI)			40K7 (4000K CCT, 70CRI)			50K7 (5000K CCT, 70CRI)			LLD @ 25°C		
			°H (50%)	°V (50%)	°H (10%)	°V (10%)	Lumens	LPW	Max CD	Lumens	LPW	Max CD	Lumens	LPW	Max CD	Lumens	LPW	Max CD	50K Hours	75K Hours	100K Hours
			P1	193	NSP	16.4	16.1	34.2	33.9	25,797	134.0	188,491	27,516	143.0	201,058	29,236	152.0	213,624	29,236	152.0	213,624
RN	67.2	19.7			96.6	41	26,260	137.0	48,468	28,011	146.0	51,699	29,761	155.0	54,931	29,761	155.0	54,931			
RM	77.2	32.4			127	57	25,787	134.0	26,737	27,506	143.0	28,520	29,225	152.0	30,302	29,225	152.0	30,302			
RW	85.6	49.8			132.4	107.6	23,938	125.0	18,419	25,533	133.0	19,646	27,129	141.0	20,874	27,129	141.0	20,874			
WG	100.7	32.8			144.5	91.8	24,497	128.0	20,367	26,130	136.0	21,725	27,763	145.0	23,082	27,763	145.0	23,082			
P2	220	NSP	16.4	16.1	34.2	33.9	28,980	132.0	211,750	30,912	141.0	225,867	32,844	149.0	239,983	32,844	149.0	239,983	0.963	0.940	0.916
		RN	67.2	19.7	96.6	41	29,500	134.0	54,449	31,467	143.0	58,079	33,434	152.0	61,709	33,434	152.0	61,709			
		RM	77.2	32.4	127	57	28,969	132.0	30,036	30,900	140.0	32,039	32,832	149.0	34,041	32,832	149.0	34,041			
		RW	85.6	49.8	132.4	107.6	26,891	122.0	20,691	28,684	130.0	22,071	30,477	139.0	23,450	30,477	139.0	23,450			
		WG	100.7	32.8	144.5	91.8	27,520	125.0	22,880	29,354	133.0	24,405	31,189	142.0	25,931	31,189	142.0	25,931			
P3	240	NSP	16.4	16.1	34.2	33.9	31,108	130.0	227,300	33,182	138.0	242,453	35,255	147.0	257,606	35,255	147.0	257,606	0.963	0.940	0.916
		RN	67.2	19.7	96.6	41	31,667	132.0	58,447	33,778	141.0	62,344	35,889	150.0	66,240	35,889	150.0	66,240			
		RM	77.2	32.4	127	57	31,096	130.0	32,242	33,169	138.0	34,391	35,242	147.0	36,541	35,242	147.0	36,541			
		RW	85.6	49.8	132.4	107.6	28,866	120.0	22,211	30,790	128.0	23,691	32,715	136.0	25,172	32,715	136.0	25,172			
		WG	100.7	32.8	144.5	91.8	29,541	123.0	24,560	31,510	131.0	26,198	33,479	139.0	27,835	33,479	139.0	27,835			
P4	260	NSP	16.4	16.1	34.2	33.9	33,612	129.0	245,597	35,853	138.0	261,970	38,093	147.0	278,343	38,093	147.0	278,343	0.963	0.940	0.916
		RN	67.2	19.7	96.6	41	34,216	132.0	63,152	36,497	140.0	67,362	38,778	149.0	71,572	38,778	149.0	71,572			
		RM	77.2	32.4	127	57	33,599	129.0	34,837	35,839	138.0	37,160	38,079	146.0	39,482	38,079	146.0	39,482			
		RW	85.6	49.8	132.4	107.6	31,190	120.0	23,999	33,269	128.0	25,599	35,348	136.0	27,198	35,348	136.0	27,198			
		WG	100.7	32.8	144.5	91.8	31,918	123.0	26,537	34,046	131.0	28,306	36,174	139.0	30,075	36,174	139.0	30,075			
P5	287	NSP	16.4	16.1	34.2	33.9	36,303	126.0	265,264	38,724	135.0	282,948	41,144	143.0	300,632	41,144	143.0	300,632	0.963	0.940	0.916
		RN	67.2	19.7	96.6	41	36,956	129.0	68,209	39,419	137.0	72,756	41,883	146.0	77,304	41,883	146.0	77,304			
		RM	77.2	32.4	127	57	36,290	126.0	37,627	38,709	135.0	40,135	41,129	143.0	42,644	41,129	143.0	42,644			
		RW	85.6	49.8	132.4	107.6	33,687	117.0	25,920	35,933	125.0	27,648	38,179	133.0	29,377	38,179	133.0	29,377			
		WG	100.7	32.8	144.5	91.8	34,474	120.0	28,662	36,773	128.0	30,573	39,071	136.0	32,484	39,071	136.0	32,484			
P6	308	NSP	16.4	16.1	34.2	33.9	38,187	124.0	279,028	40,733	132.0	297,630	43,279	141.0	316,232	43,279	141.0	316,232	0.963	0.940	0.916
		RN	67.2	19.7	96.6	41	38,873	126.0	71,748	41,465	135.0	76,532	44,056	143.0	81,315	44,056	143.0	81,315			
		RM	77.2	32.4	127	57	38,173	124.0	39,579	40,718	132.0	42,218	43,263	140.0	44,857	43,263	140.0	44,857			
		RW	85.6	49.8	132.4	107.6	35,435	115.0	27,265	37,798	123.0	29,083	40,160	130.0	30,901	40,160	130.0	30,901			
		WG	100.7	32.8	144.5	91.8	36,263	118.0	30,150	38,681	126.0	32,159	41,098	133.0	34,169	41,098	133.0	34,169			
P7	328	NSP	16.4	16.1	34.2	33.9	40,294	123.0	294,425	42,981	131.0	314,054	45,667	139.0	333,682	45,667	139.0	333,682	0.963	0.940	0.916
		RN	67.2	19.7	96.6	41	41,018	125.0	75,708	43,753	133.0	80,755	46,487	142.0	85,802	46,487	142.0	85,802			
		RM	77.2	32.4	127	57	40,280	123.0	41,764	42,965	131.0	44,548	45,650	139.0	47,332	45,650	139.0	47,332			
		RW	85.6	49.8	132.4	107.6	37,391	114.0	28,770	39,883	122.0	30,688	42,376	129.0	32,606	42,376	129.0	32,606			
		WG	100.7	32.8	144.5	91.8	38,264	117.0	31,813	40,815	124.0	33,934	43,366	132.0	36,055	43,366	132.0	36,055			

### Optional Field Adjustable Performance Selector 'PS' (*'PS' is only compatible with standard 0-10V drivers, not compatible w/ optional DALI drivers*)

The optional Performance Selector is an integral dial that allows for field adjustable lumen/wattage dimming control for added design versatility. Normal tolerance +/- 8%.

#### 2700K, 3000K (5050LED Optics - N66, S33)\*

PS Position	Lumen Output %	P1	P2	P3	P4	P5	P6	P7
		Wattage (W)						
8	100%	180	211	263	290	317	345	373
7	90%	159	187	233	257	281	305	330
6	80%	143	168	209	231	252	274	297
5	70%	124	145	181	200	218	237	257
4	60%	108	127	158	174	191	207	224
3	50%	89	104	130	144	157	171	185
2	40%	71	83	104	114	125	136	147
1	30%	53	62	78	86	94	102	110

\*For 80CRI option use an additional 0.91 lumen multiplier.

#### 4000K, 5000K (5050LED Optics - N66, S33)\*

PS Position	Lumen Output %	P1	P2	P3	P4	P5	P6	P7
		Wattage (W)						
8	100%	180	211	263	290	317	345	373
7	90%	159	187	233	257	281	305	330
6	80%	143	168	209	231	252	274	297
5	70%	124	145	181	200	218	237	257
4	60%	108	127	158	174	191	207	224
3	50%	89	104	130	144	157	171	185
2	40%	71	83	104	114	125	136	147
1	30%	53	62	78	86	94	102	110

\*For 80CRI option use an additional 0.91 lumen multiplier.

#### 2700K, 3000K, 4000K, 5000K (3535LED Optics - NSP, RN, RM, RW, WG)\*

PS Position	Lumen Output %	P1	P2	P3	P4	P5	P6	P7
		Wattage (W)						
8	100%	192	220	240	260	287	308	328
7	90%	170	195	212	230	254	273	290
6	80%	153	175	191	207	228	245	261
5	70%	132	151	165	179	197	212	226
4	60%	115	132	144	156	172	185	197
3	50%	95	109	119	129	142	152	162
2	40%	76	87	95	102	113	121	129
1	30%	57	65	71	77	85	91	97

\*For 80CRI option use an additional 0.91 lumen multiplier.

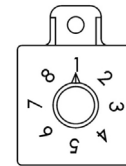

Optional Field Adjustable Performance Selector 'PS' Dial

### IES TM-21 LED Lumen Maintenance (*\*values italicized are per LM-80 data that is extrapolated beyond the TM-21 6X standard*)

Reported lumen maintenance life projections are based on 6X the duration of the LED's IES LM-80 tested performance data in accordance per IES TM-21 guidelines.

5050LED Optics P1 to P3	IES TM-21 LED Lumen Maintenance					
	0 Hrs	25,000 Hrs	50,000 Hrs	60,000 Hrs	*75,000 Hrs	*100,000 Hrs
VTL @ 25°C Ambient	100.00%	98.60%	97.89%	97.61%	<i>97.19%</i>	<i>96.49%</i>
VTL @ 50°C Ambient	100.00%	96.10%	93.24%	92.12%	<i>90.47%</i>	<i>87.78%</i>

5050LED Optics P4 to P7	IES TM-21 LED Lumen Maintenance					
	0 Hrs	25,000 Hrs	50,000 Hrs	60,000 Hrs	*75,000 Hrs	*100,000 Hrs
VTL @ 25°C Ambient	100.00%	96.65%	94.23%	93.27%	<i>91.86%</i>	<i>89.56%</i>
VTL @ 50°C Ambient	100.00%	94.86%	91.48%	90.16%	<i>88.22%</i>	<i>85.07%</i>

3535LED Optics	IES TM-21 LED Lumen Maintenance					
	0 Hrs	25,000 Hrs	50,000 Hrs	60,000 Hrs	*75,000 Hrs	*100,000 Hrs
VTL @ 25°C Ambient	100.00%	98.75%	96.32%	95.37%	<i>93.95%</i>	<i>91.64%</i>
VTL @ 50°C Ambient	100.00%	97.53%	93.86%	92.43%	<i>90.33%</i>	<i>86.94%</i>

**Optical Isofootcandle Plots** ('P17' Performance Code, 4000K/5000K, 70CRI, 25' Mounting Height MH, Grid Scale = MH or 25' as shown)

Complete non-shielded & shielded photometric IES files are available for download at [www.LEOTEK.com](http://www.LEOTEK.com) or can be found in AGI32's Photometric Instabase.

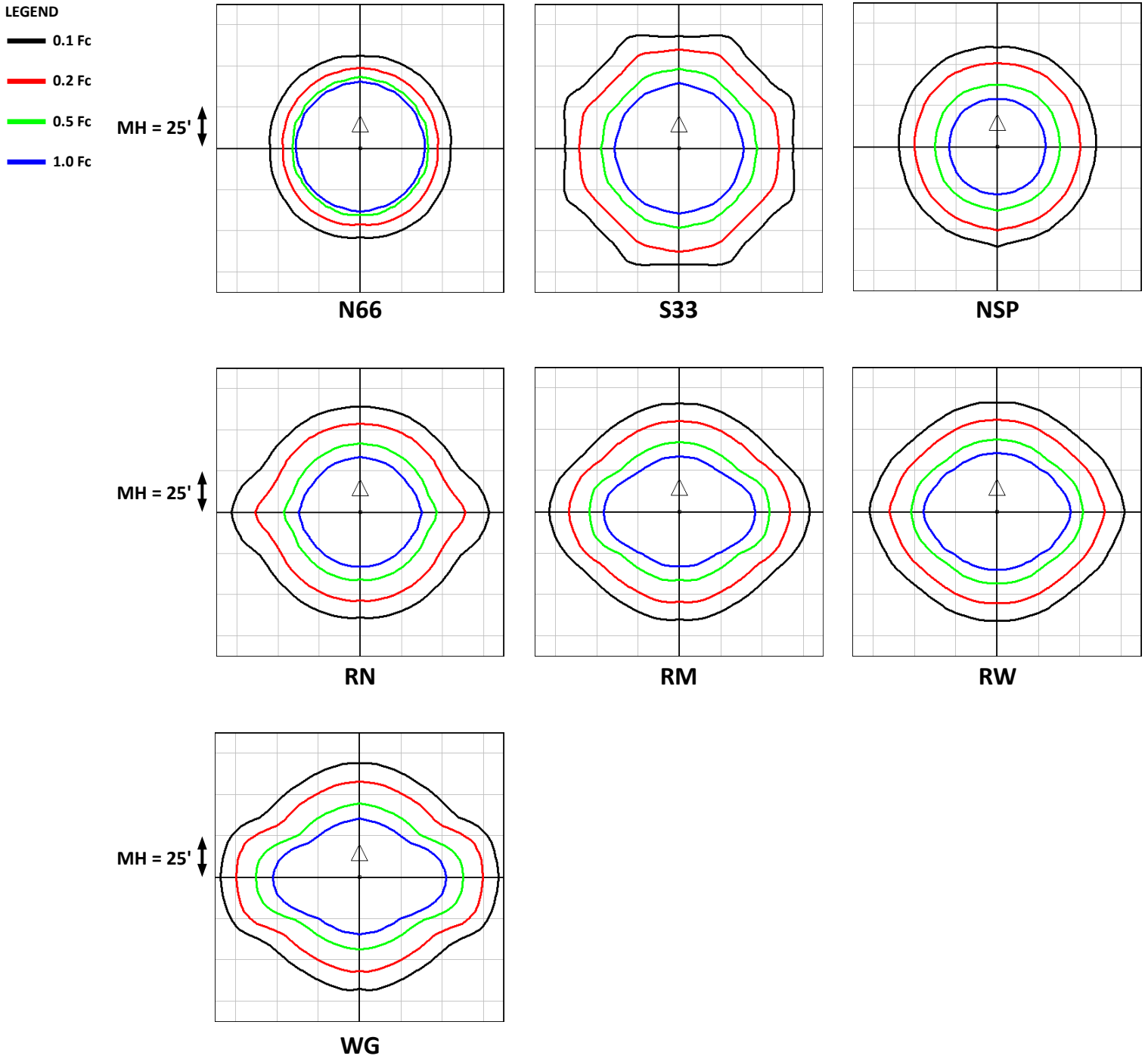

### Mounting Option Details & Dimensional Information

#### 'SF' Slipfitter Mount #1\*

(available wire leads in UL splice compartment)  
(shown w/ optional 'PCR7CR')

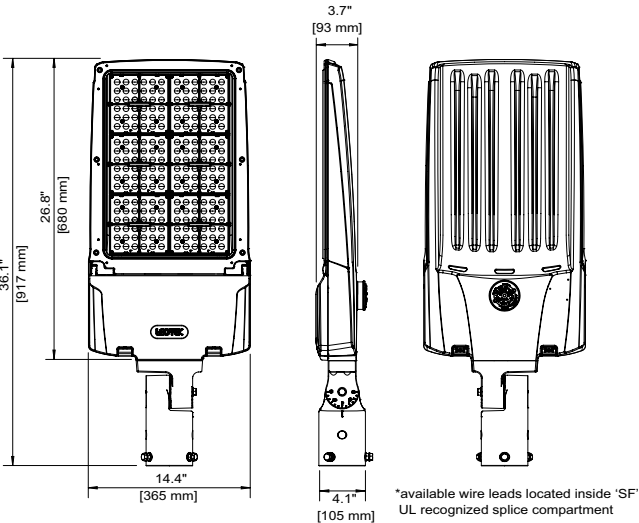

#### 'SFC' Slipfitter #2\*

(w/ 3-wire S/O Cord Center Fitter Exit)

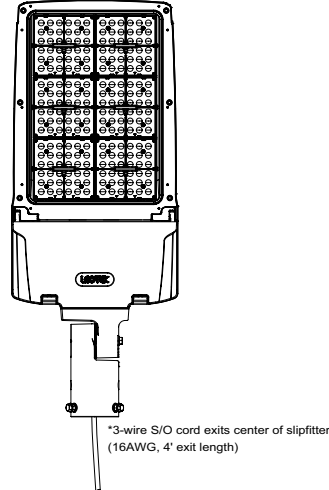

#### 'SFH' Slipfitter #3\*

(w/ 3-wire S/O Cord Bottom Housing Exit)

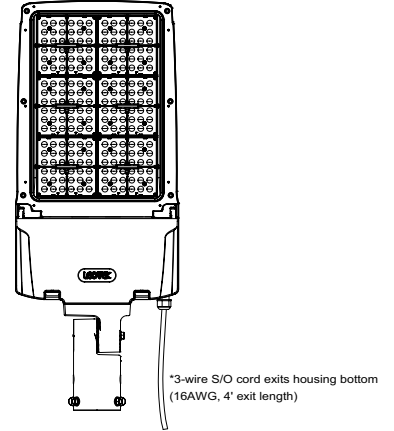

#### 'TR' Trunnion Mount\*

(shown w/ optional 'PCR7CR')

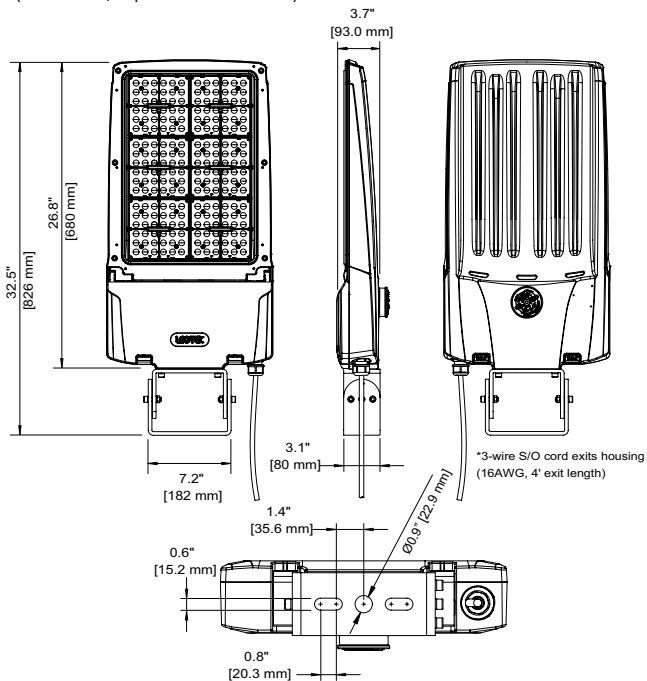

#### 'YK' Yoke Mount\*

(shown w/ optional 'PCR7CR')

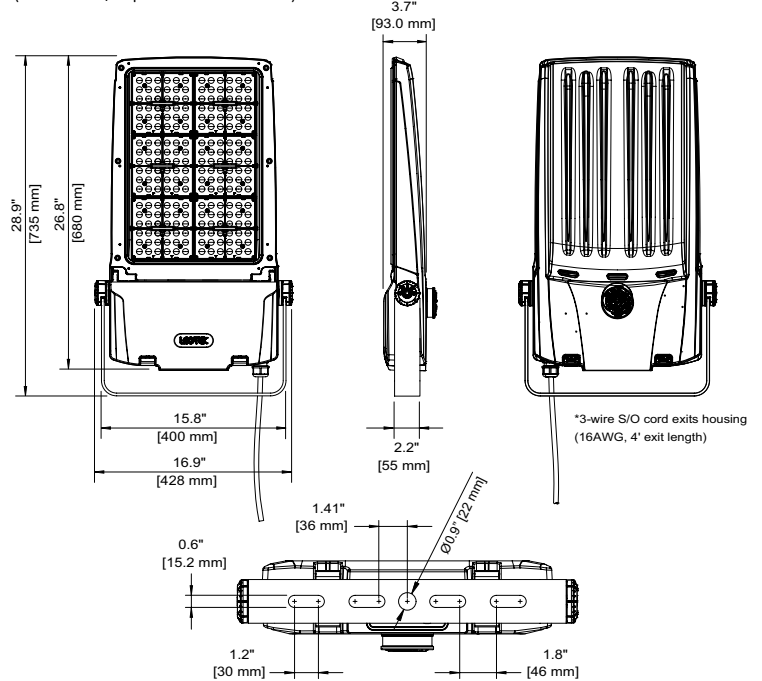

### Mounting Option Details & Dimensional Information

#### 'AWM' Adjustable Wall Mount\*

(mounts to recessed J-box, shown w/ optional 'PCR7CR')

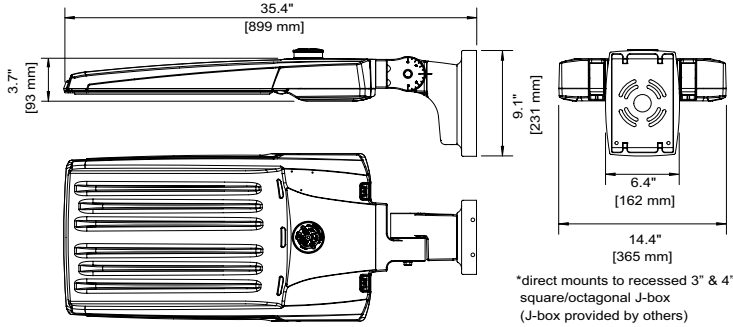

#### 'AWMSC' Adjustable Wall Mount Surface Conduit\*

(includes surface mount 3/4" conduit J-box, shown w/ optional 'PCR7CR')

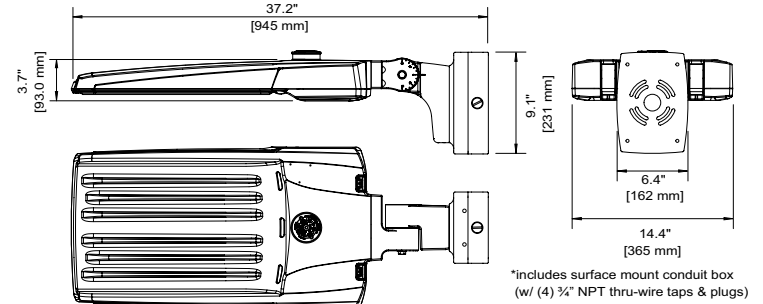

#### 'ASPM' Square & 'ARPM' Adjustable Round Pole Arm Mount\*

(quick mount arm can retrofit up to 5.25" max. bolt spacing w/ no drilling required)

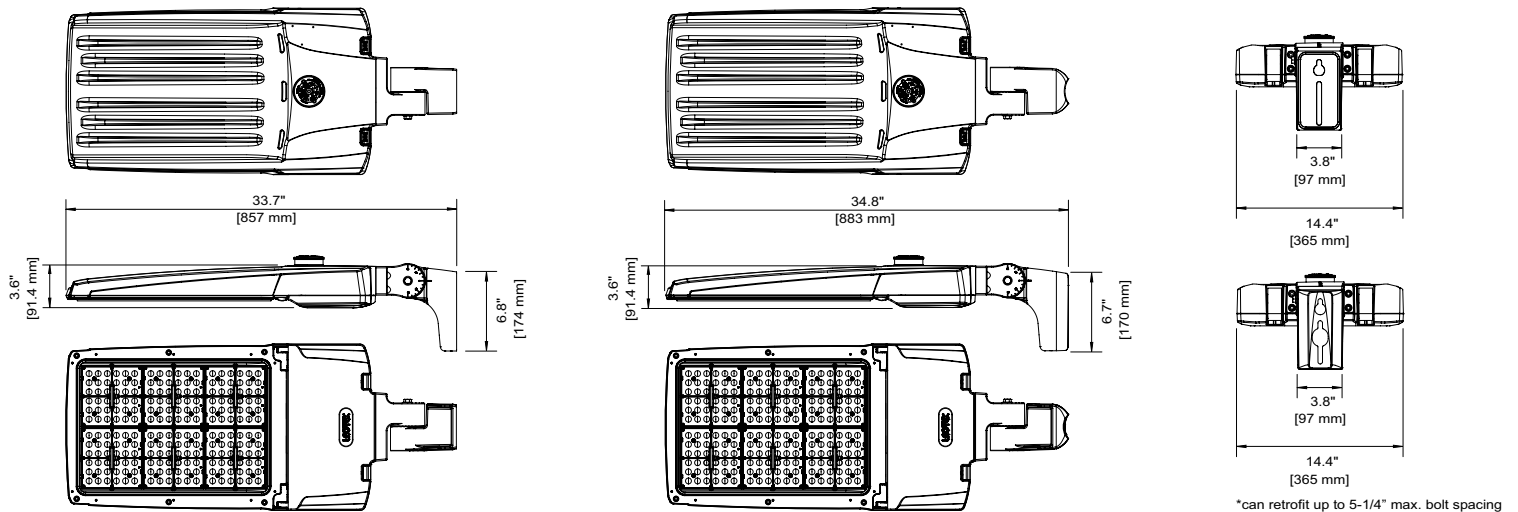

### Key Additional Miscellaneous Product Features & Design Details

#### Integral Tool-Free Access Design

Tool-free electrical access & removable hinged door w/ fixed open door prop design for ease of installation or maintenance  
(compatible w/ most lineman safety gloves)



#### Slipfitter w/ UL Splice Box

'SF' Slipfitter w/ integral UL recognized splice compartment  
(w/ available wire lead access & WAGOs for ease of installation)



#### Self-Centering Design

Slipfitter options are designed with a self-centering & leveling design feature  
(compatible w/ 1-5/8", 2-3/8" & 3" O.D. tenons)

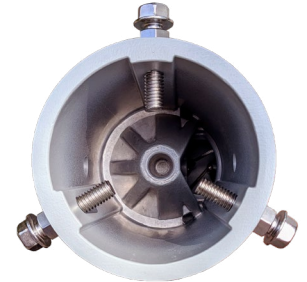

#### 3-Position Terminal Block 'TB' Option

For ease of maintenance & increased safety, improved wire management & robust product life cycle operation  
(includes line, neutral & ground, accommodates 6 to 16AWG wire)

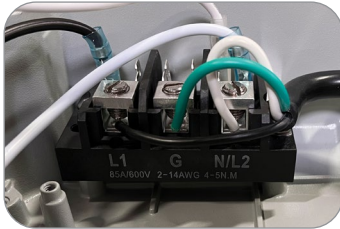

#### Performance Selector 'PS' Option

Allows for quick & easy field adjustment of wattage, lumen output and reduced SKU complexity  
(fixed position dial ensures correct output setting)

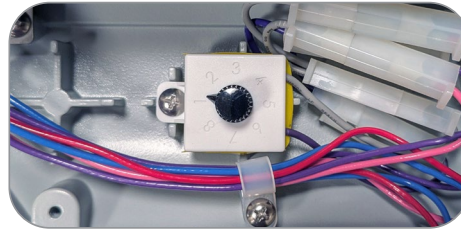

#### Integral VersaKick

VersaKick 'kickstand' props open the door during installation or maintenance  
(allows for 'frustration free' ease of access)



#### Pass-Thru Convective Cooling

(3) integral cooling slots allows ambient air to flow freely thru the luminaire for enhanced thermal management  
(maximizes lifetime of electrical components & lumen maintenance)



#### Tool-Free Removable Power Door Option 'PWRD'

All serviceable electrical components are mounted to a tool-free removable Power Door that can be removed in less than 15 seconds to safely service on the ground or replace in seconds  
(undo MOLEX connectors, push two spring clips inward to unlock door, slide the door forward & lift to remove)

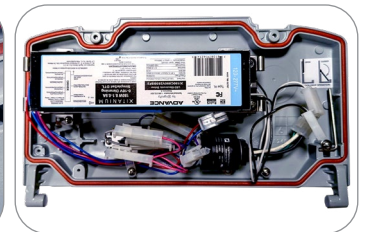
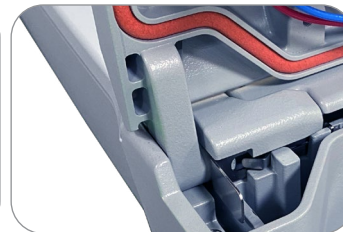

#### '4SS-VTL'

4-Sided Shield



#### 'TBS-VTL'

Top or Bottom Shield



#### 'LRS-VTL'

Left or Right Side Shield



#### 'BDS-VTL'

Barn Door Shield



#### 'WG-VTL'

Wire Guard



#### 'VS-VTL'

Poly Vandal Shield



### LEOLink ILS™ Intelligent Lighting System for Tomorrow's Smart & Sustainable Cities

#### Smart...Scalable...Effortless

LEOLink ILS is the next evolution in street lighting, integrating AI and IoT to transform a city's traditional outdoor lighting infrastructure into a smart, adaptive network. It empowers municipalities and utilities with real-time control, predictive maintenance, and rapid scalability, all with unmatched simplicity.

Integrating LEOTEK's AI-driven centralized management platform (LEOLink RenAI) with intelligent streetlight controllers, LEOLink ILS provides 24x7 visibility into the status and performance of streetlights enabling efficient energy use, real-time fault detection, and predictive maintenance across city-wide lighting networks. Easy "plug-and-play" deployment and scalability support users in achieving operational excellence, public safety, and long-term sustainability. With LEOLink ILS, cities are creating the backbone of a future-ready smart city.

### Key Functions

#### Centralized, Remote Management

Gain complete control of your city's smart lighting infrastructure from a single, intuitive platform.

#### Instant Response to Anomalies

Automatically identify and respond to abnormal lighting behavior in real-time.

#### AI-Powered Predictive Maintenance

Detect and address faults before they occur, minimizing downtime and maintenance costs.

#### Actionable Insights Through Data Visualization

Monitor asset performance and energy trends with clear, interactive dashboards and reports.

#### Energy Efficiency & Cost Savings

Optimize energy usage with intelligent scheduling and dimming, reducing operational expenses.

### LEOLink NB01 Plus Smart Controller Key Features & Benefits

The smartest fit for 7-PIN NEMA fixtures. Engineered to deliver seamless performance, trusted security, and plug-and-play simplicity, all in one powerful, next-generation controller.



\*LEOLink 'NB01P' Smart Controller

Model	Form Factor	Fixture Compatibility	Connectivity	Power Source	Typical Use Case
NB01 Plus	NEMA 7-pin	Most ANSI C136.41-compliant fixtures	NB-IoT / LTE CAT-M	Powered via NEMA socket	Retrofit or upgrade existing fixtures



#### Self-Monitoring & Fault Detection

NB01P continuously monitors the luminaire's operational status, identifying power outages, failures, and abnormal energy patterns for fast diagnostics and improved maintenance efficiency.



#### AI-Driven Adaptive Dimming

Participates with LEOLink RenAI to enable intelligent dimming strategies, including human-centric lighting adjustments based on real-time traffic, weather, and pedestrian activity.



#### Ultra-High Connectivity

Dual-mode cellular communication using the world's most reliable and secure carriers ensures a 99.5% connection success rate, delivering reliable continuous data transmission even in challenging environments.



#### Predictive Maintenance & Analytics

Advanced failure analysis and predictive diagnostics move cities from reactive to preventative maintenance strategies that reduce downtime and operational costs.



#### Built-In Surge Protection

Advanced surge protection against lightning and voltage spikes safeguards critical streetlight infrastructure.

### LEOLink RenAI Central Management System Key Features & Benefits

An AI-powered cloud-based streetlight Central Management System (CMS), LEOLink RenAI is at the core of the LEOLink Intelligent Lighting System (ILS). Unlike traditional CMS platforms, LEOLink RenAI, leverages a native AI foundation to transform streetlighting into a dynamic, adaptive, and self-optimizing system by analyzing real-time and historical data. Designed to meet the complex demands of modern roadway infrastructure, LEOLink RenAI helps municipalities improve energy efficiency, reduce operational costs, and improve public safety across city-wide lighting networks.



#### LiSA (LEOTEK intelligent Service Advisor)

LiSA, our AI-powered assistant, is available 24/7 to streamline operations, quickly answering questions, generating charts and tables, and assisting with troubleshooting to lighten your team's workload.



#### Fault Detection & Notification

Monitor streetlight health and status in real time to detect and receive instant fault alerts.



#### Asset Management

Collect and track roadway infrastructure asset information such as streetlight fixtures, poles and controllers. to drive operational efficiencies across from field maintenance to life cycle management.



#### Energy Consumption Management

Track usage, identify trends, and forecast energy needs for optimal efficiency.



#### Remote Control

Remotely switch lights ON/OFF and adjust brightness via an intuitive user interface.



#### Data Analysis & Reporting

Access historical insights, visualize data, and generate reports for informed decision-making.



#### Scheduled Dimming

Automatically adjusts brightness levels based on ambient light and pre-set schedules.

**Part-Night Dimming Specifications**

**Description**

Part-Night Dimming (PND) option enables significant energy savings by automatically dimming the luminaire during early morning hours when infrequent use is expected. Factory programmed dimming profiles automatically take into account seasonal changes based on geographical location by continuously monitoring the nighttime midpoint. PND does not provide power on/off control which is provided by external controls (example: time clock or a photocontrol using 'PCR7CR' option). Dimming profile of PND option is not field adjustable.

**Operation**

Based on the PND profile that is selected, the luminaire dims to the corresponding % power for the corresponding length of time (based on the nighttime mid-point) as shown below. Mid-point is continuously recalculated in the luminaire by monitoring the average length of time between when the light turns on (power on) and turns off (power off) over the previous two days. In effect, this functionality will take two days to initialize after installation before any dimming will occur. Power interruptions are ignored and do not affect the determination of mid-point. Three factory programmed PND profiles are available for selection:

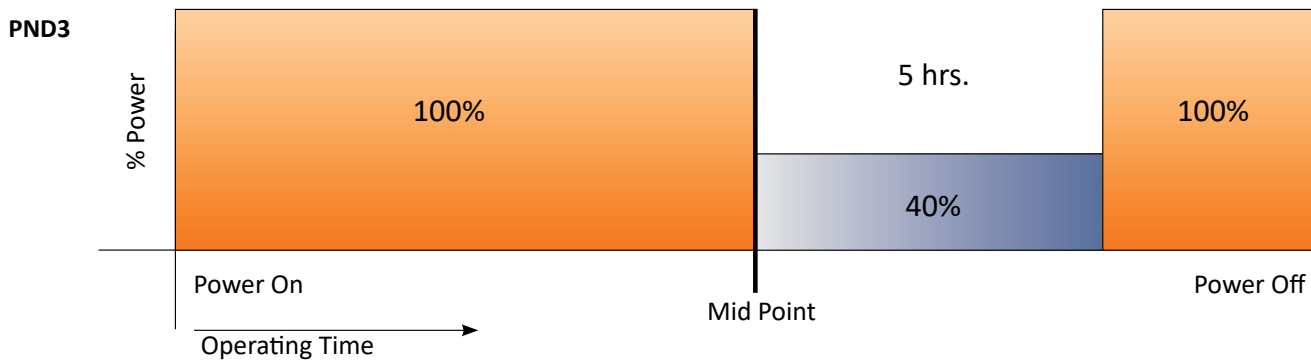
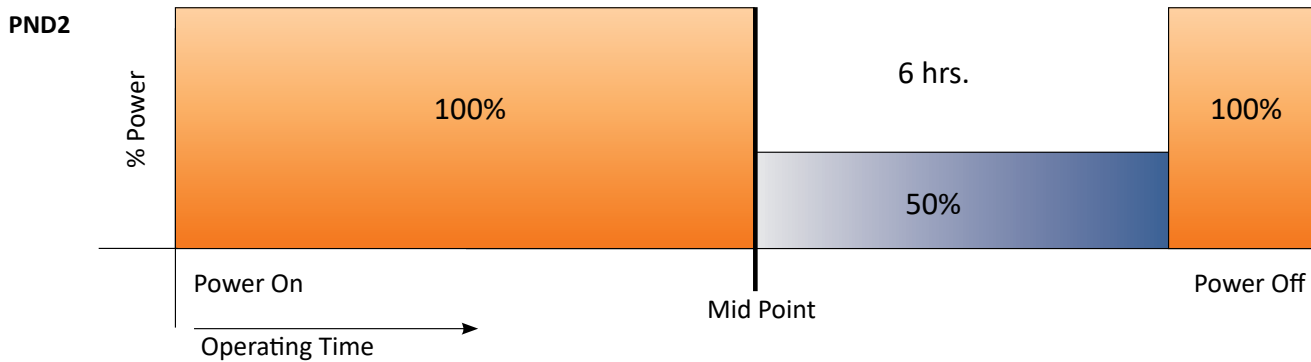
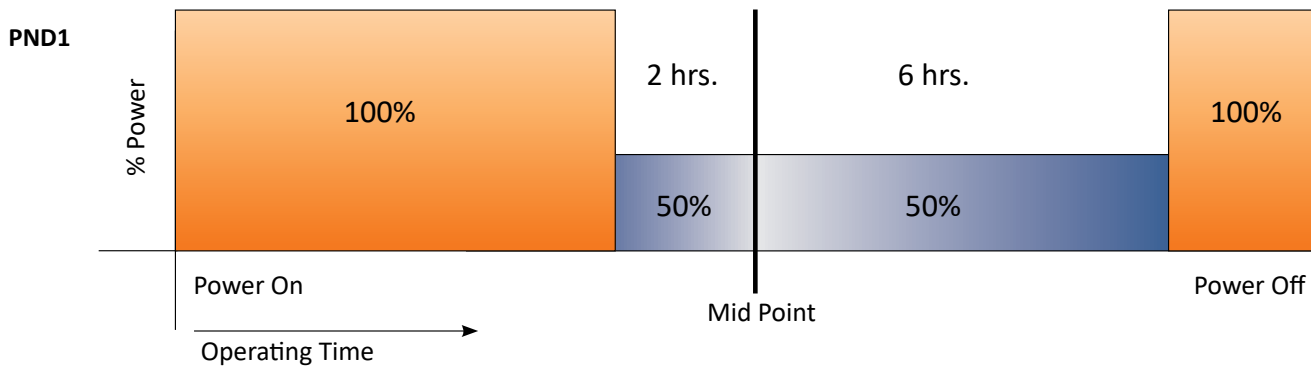

### VersaTEK Large LED Flood - Luminaire EPA Values

(\*Includes luminaire and mounting options shown. Secondary tenons, brackets or other accessories are not included in the EPA data.)

Luminaire Quantity & Orientation		Effective Projected Area (EPA ft <sup>2</sup> )								
		Single	2 @ 90	2 @ 180	3 @ 90	3 @ 120	4 @ 90	2 Side by Side	3 Side by Side	4 Side by Side
Mounting Option	Tilt									
SF Slip Fitter	0°	1.14	1.59	2.28	2.72	2.30	2.72	0.90	1.34	1.79
	10°	1.14	1.86	2.28	3.00	2.82	3.00	1.45	2.17	2.89
	20°	1.24	2.37	2.28	3.51	3.76	3.51	2.47	3.71	4.94
	30°	1.72	2.86	2.28	3.99	4.69	3.99	3.44	5.15	6.87
	40°	2.16	3.30	2.28	4.43	5.55	4.43	4.31	6.47	8.63
SFC Slip Fitter Center	45°	2.35	3.49	2.35	4.63	5.94	4.63	4.71	7.06	9.42
	50°	2.54	3.67	2.54	4.81	6.30	4.81	5.07	7.61	10.14
	60°	2.84	3.98	2.84	5.12	6.91	5.12	5.68	8.52	11.36
	70°	3.06	4.20	3.06	5.34	7.36	5.34	6.12	9.19	12.25
SFH Slip Fitter Housing	80°	3.20	4.34	3.20	5.48	7.65	5.48	6.41	9.61	12.82
	90°	3.26	4.39	3.26	5.53	7.76	5.53	6.51	9.77	13.02
	0°	0.86	1.34	1.71	2.20	2.01	2.20	0.97	1.46	1.94
	10°	0.86	1.62	1.73	2.49	2.55	2.49	1.52	2.27	3.03
YK Yoke Mount	20°	1.24	2.13	1.78	3.02	3.47	3.02	2.48	3.72	4.96
	30°	1.70	2.61	1.82	3.53	4.39	3.53	3.40	5.10	6.80
	40°	2.12	3.04	2.12	3.96	5.22	3.96	4.23	6.35	8.46
	45°	2.30	3.22	2.30	4.15	5.58	4.15	4.60	6.90	9.20
	50°	2.47	3.40	2.47	4.32	5.92	4.32	4.94	7.41	9.88
	60°	2.75	3.68	2.75	4.61	6.48	4.61	5.51	8.26	11.01
	70°	2.95	3.88	2.95	4.81	6.89	4.81	5.91	8.86	11.82
	80°	3.08	4.02	3.08	4.95	7.15	4.95	6.17	9.25	12.33
	90°	3.12	4.06	3.12	4.99	7.24	4.99	6.24	9.36	12.48
	TR Trunnion Mount	0°	0.97	1.41	1.93	2.38	2.10	2.38	0.89	1.34
15°		0.99	1.96	1.93	2.92	3.10	2.92	1.98	2.97	3.96
30°		1.75	2.72	1.93	3.68	4.57	3.68	3.50	5.25	7.00
45°		2.40	3.36	2.40	4.33	5.85	4.33	4.80	7.19	9.59
60°		2.89	3.85	2.89	4.82	6.83	4.82	5.77	8.66	11.54
75°		3.22	4.18	3.22	5.15	7.48	5.15	6.43	9.65	12.86
ASPM & ARPM Adjustable Square & Round Pole Arm Mount	90°	3.32	4.29	3.32	5.26	7.71	5.26	6.65	9.97	13.29
	0°	1.03	1.60	2.07	2.63	2.44	2.63	1.13	1.69	2.25
	10°	1.03	1.89	2.07	2.93	2.97	2.93	1.72	2.58	3.44
	20°	1.37	2.40	2.07	3.44	3.91	3.44	2.74	4.10	5.47
	30°	1.85	2.89	2.07	3.92	4.85	3.92	3.70	5.55	7.40
	40°	2.29	3.32	2.29	4.36	5.71	4.36	4.58	6.86	9.15
	45°	2.49	3.52	2.49	4.56	6.10	4.56	4.97	7.46	9.94
	50°	2.67	3.70	2.67	4.74	6.46	4.74	5.33	8.00	10.66
	60°	2.97	4.01	2.97	5.04	7.06	5.04	5.94	8.91	11.88
	70°	3.19	4.23	3.19	5.26	7.52	5.26	6.39	9.58	12.77
80°	3.34	4.37	3.34	5.41	7.81	5.41	6.67	10.01	13.34	
90°	3.38	4.42	3.38	5.45	7.92	5.45	6.77	10.15	13.54	

### Adjustable Square & Round Pole Arm Mount Drilling Dimensions for New Construction

(for additional details, please consult online installation instructions)

