

# SafeGuard™

## Utility Light Series



A Multi-Purpose  
Luminaire for Security,  
Dusk to Dawn, Street and  
Area Light Applications



**LEOTEK®**

[www.leotek.com](http://www.leotek.com)



The SafeGuard LED Security Light is a reliable, energy efficient, and economical option for a variety of applications.



# UTL Utility Series

Security, Dusk to Dawn, Street and Area Light Applications

## Dimensions & Profile

<b>Weight</b>	6.4 lbs (2.9 kg)
<b>EPA</b>	.33 sq. ft.
<b>Width</b>	8.15" [208 mm]
<b>Height</b>	4.8" [122mm]

## SafeGuard UTL1

UTL1

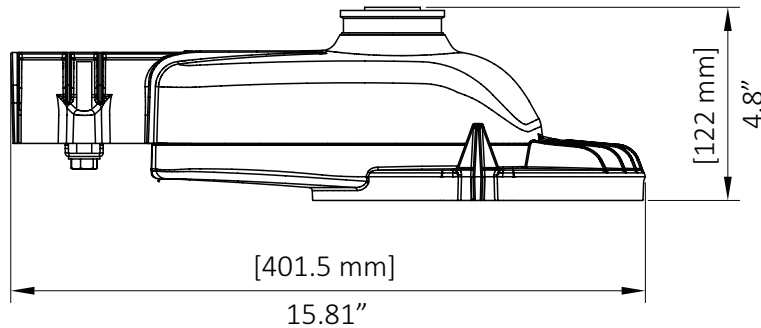

## UTL1 with Nema Drop-Down Refractor

UTL1- DR

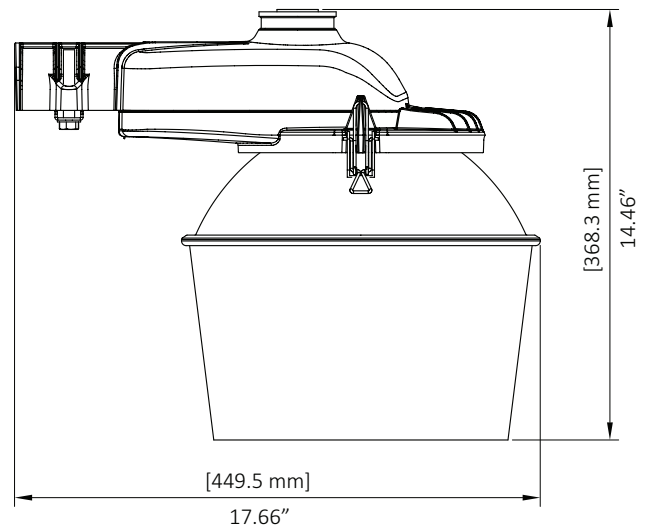
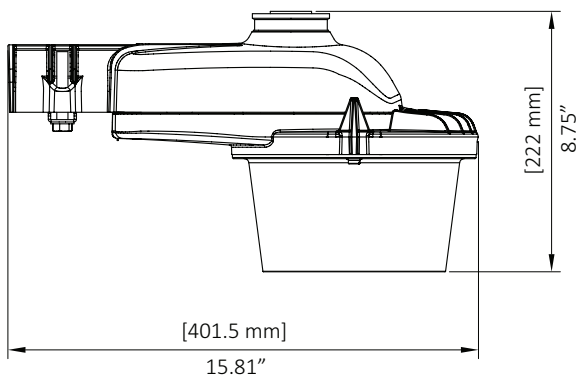

## Lumen Range and HPS Equivalents

HPS	Wattage (W)	50W	100W	150W	175W	200W
UTL with DR	Wattage (W)	21W	34W	37W	46W	54W
	Lumens (lm)	3150	4771	5316	6367	7365
	Output Code Range (4000K)	035	050	055	065	075



### Robust, Efficient LED Light Engines

Light engines are designed to draw less current than most designs in the industry, which provides maximum efficacy with less thermal stress for longer life. LEDs are ROHS compliant, 100% mercury and lead-free. IP-66 rated light engines use an array of discrete LEDs. There is less glare since the LED light sources are distributed, not concentrated in a small area like COB (chip-on-board) light engines.



### Control Ready for Wireless Nodes

Available "PCR7-CR" industry-standard photocell receptacle for the attachment of standard photocells or 'smart' control-nodes.

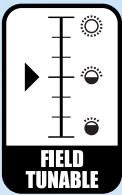

### Light Level Control Options

The dimmable power supply enables field-adjustable light levels with the optional rotary dial current selector. Continuous dimming is also available using a compatible wireless dimming node.



### High Efficacy

Efficacy up to 150 lm/W



### Vandal Resistant

LED optics are IK10 rated, the highest rating for impact resistance.



### Power Supplies & Surge Protection

Luminaires are designed with power supplies that are rated for 100,000 hours of life with standard 1-10V dimming.

Surge Protection: Standard 4kV. Optional 10kV/5kA (SP1) and 20kV/10kA (SP2) per ANSI C136.2-2015



### Rigorous Testing and Certification Process

Luminaires are carefully assembled and tested at LEOTEK's USA facility in San Jose, California. The light engines are 100% tested prior to assembly. Every luminaire is 100% performance tested after 2-hour burn-in period.

LEOTEK believes that good design integrates simplicity and functionality. The UTL Series is built with durable high-strength materials and reliable components, and is backed by LEOTEK USA's Standard 5-Year Warranty and 30 years of experience building LED lighting products.

### Easy Installation & Maintenance

Tool-less access to wiring compartment via stainless-steel latch.

### Control Ready for Wireless Nodes

3-Wire photocontrol receptacle is standard. ANSI C136.41 7-wirePCR7-CR photocontrol receptacle is optional.

Accommodates Standard Dropdown and NEMA Dropdown Refractors

### Multi-position Current Selector

### 3-position Terminal Block

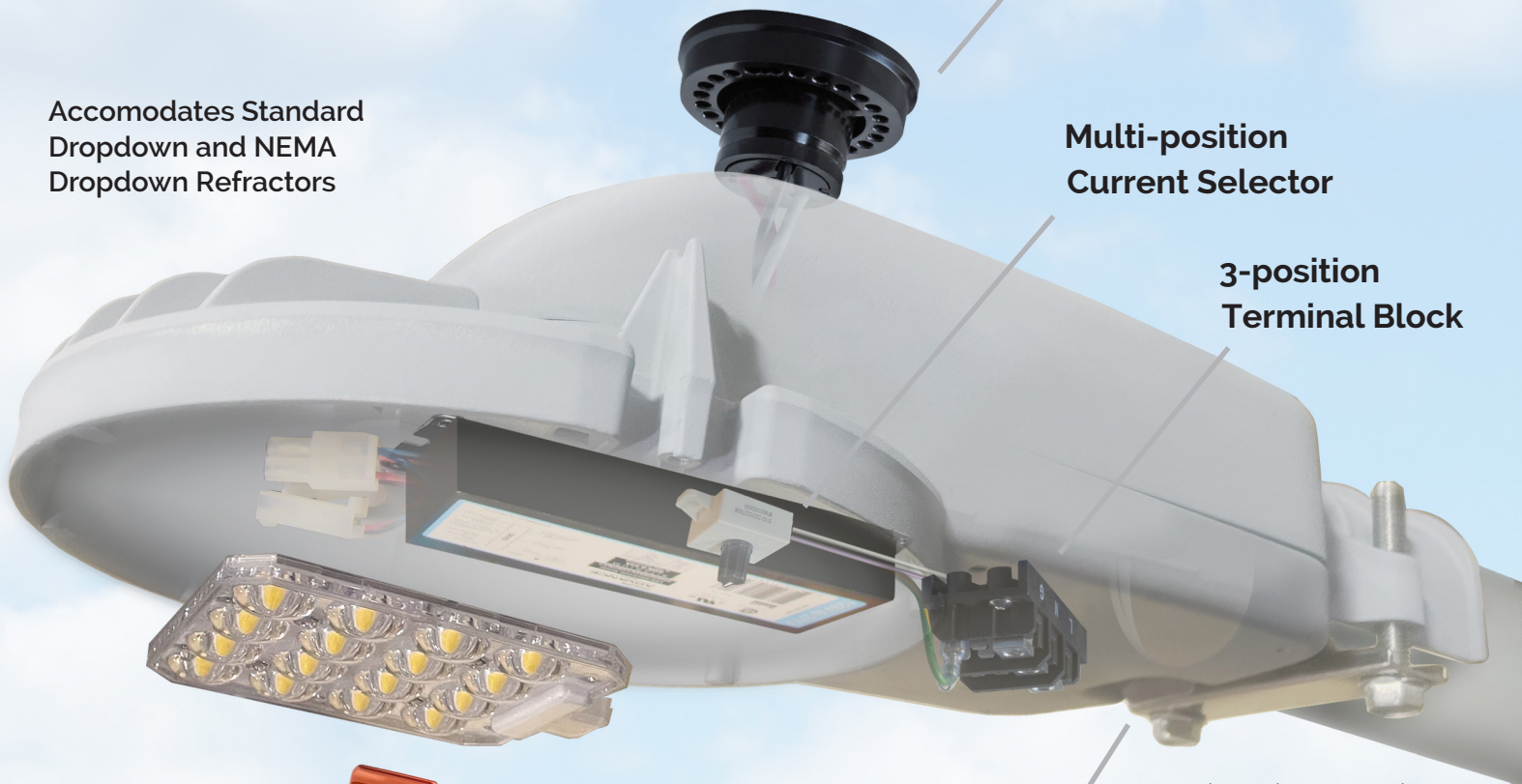

\*Internal components shown for illustration purposes only.

### Stainless Steel, Captive, Quick-release Latch



### Color Temperature Filter (CTF)

Optional filter provides 2200K and 2700K options for applications that require warmer color temperatures.

### Standard Finishes

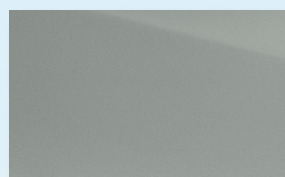

Grey

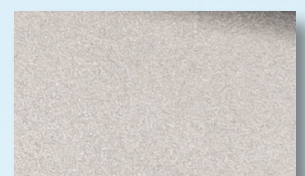

Natural Aluminum

## Distribution Types

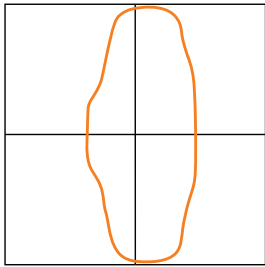

Type 2

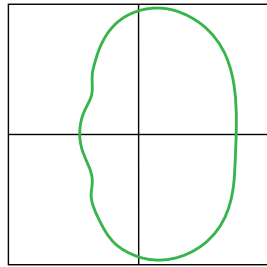

Type 3

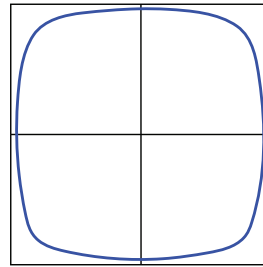

Type 5

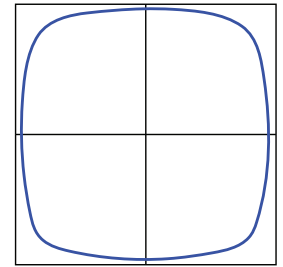

Drop Down Refractor (DR) with Type 5

LEOTEK luminaires feature a variety of options to accommodate “field-tuning” of light levels and light distribution. In addition, options are available to facilitate the integration of wireless controls.

## Field-Tuning of Light Levels

Luminaires include a dimmable 1-10V power supply with optional output selector (CS). This enables end users to easily change light levels in the field if necessary.

### Multi-step Current Selector

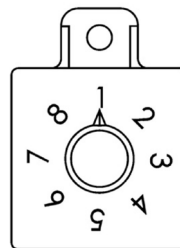

1	54_530
2	46_450
3	37_370
4	34_330
5	21_205
6, 7, 8	54_530

## Field-Tuning of Color Temperature

The unique Color Temperature Filter (CTF) provides 2200K and 2700K options for applications that require warmer color temperatures

Color Temperature Filter  
Part# CTFUTL16

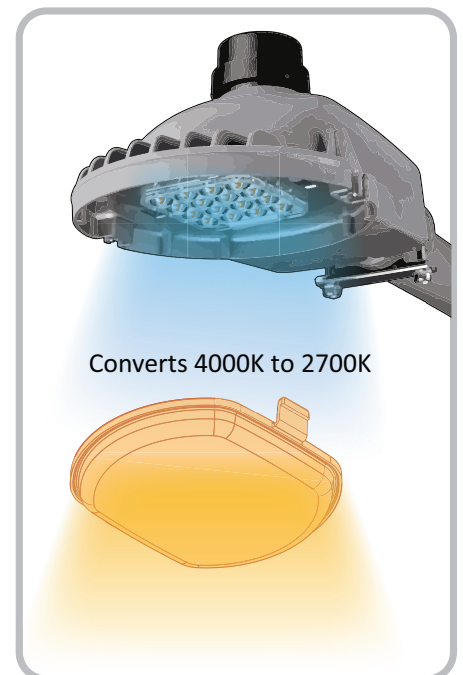
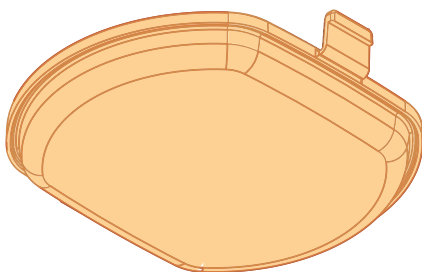

## Refractor Options

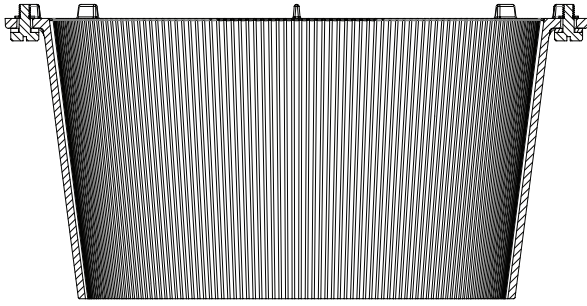

Dropdown Refractor Lens  
Part# DR

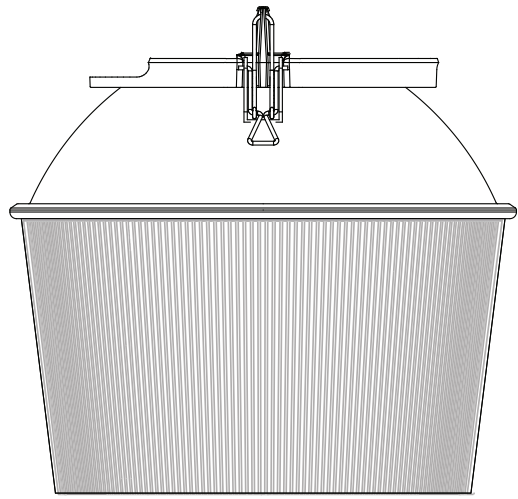

NEMA Dropdown Lens  
(Provided by others)

## Light Trespass Shielding

LEOTEK's Universal Light Trespass Shields Allow for Easy Snap-on Field Installation

Snap-on shields may be purchased for either field or factory installation. Shields fit completely inside the housing profile.

### Snap-on Front Side Shield (FSS)

Part# FSSUTL16

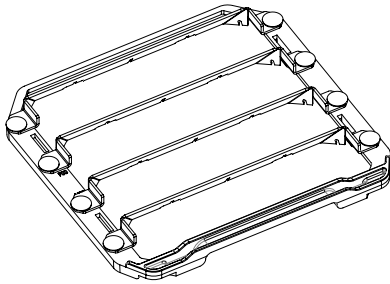

Type 2 Light Distribution with FSS

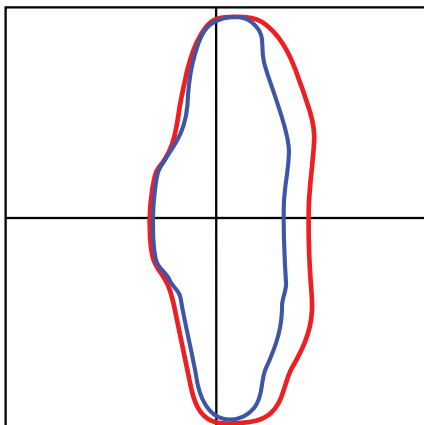

### Snap-on House Side Shield (HSS)

Part# HSSUTL16

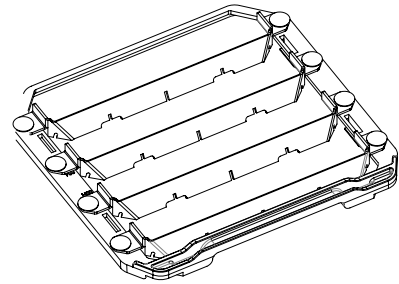

Type 2 Light Distribution with HSS

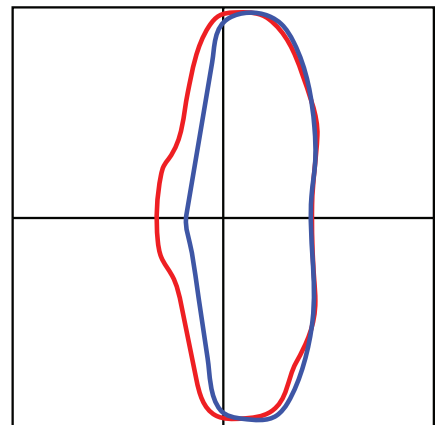

With Shield: ■ Without Shield: ■

# Mounting Accessories

**PTB- Pole Top Tenon Horizontal Arm Bracket**

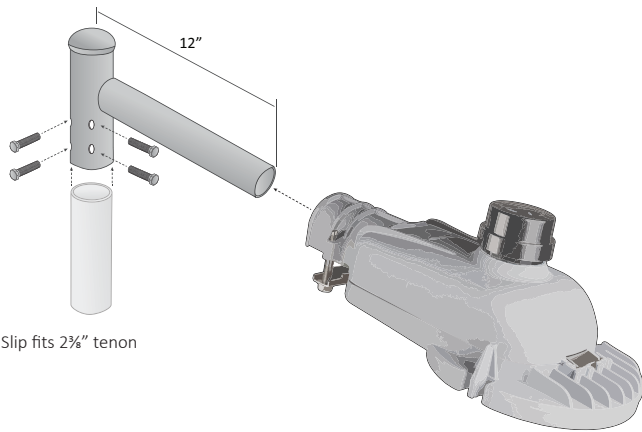

Slip fits 2 3/4" tenon

Mounting Hardware provided with bracket  
3/8"-16 X 3/4" H.H.C.S. (2 SETS OF 2 @ 90°)

**PTB2- Pole Top Tenon Horizontal Arm Bracket (2@180°)**

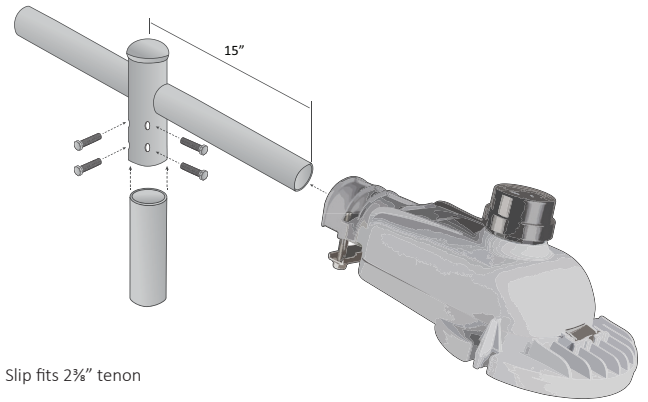

Slip fits 2 3/4" tenon

Mounting Hardware provided with bracket  
3/8"-16 X 3/4" H.H.C.S. (2 SETS OF 2 @ 90°)

**RPB- Round Pole Horizontal Arm Bracket**

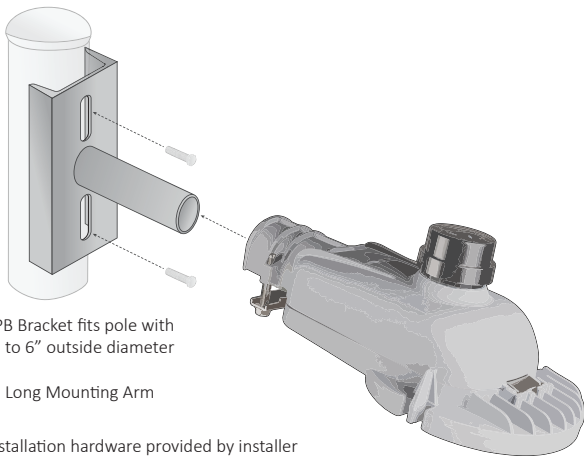

RPB Bracket fits pole with  
3" to 6" outside diameter

6" Long Mounting Arm

Installation hardware provided by installer

**PA-18 - 18" Pipe Arm Accessory**

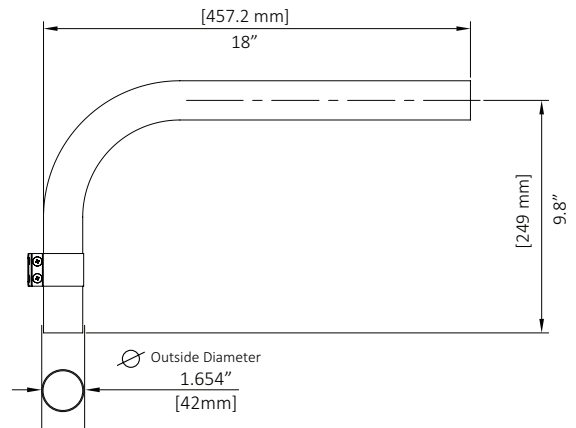

**PA-24 - 24" Pipe Arm Accessory**

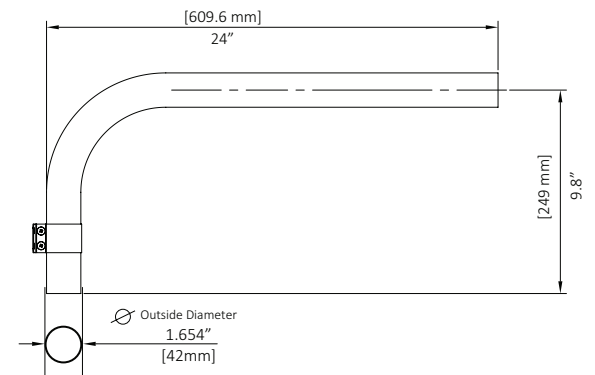

**WB- Wall Horizontal Arm Bracket**

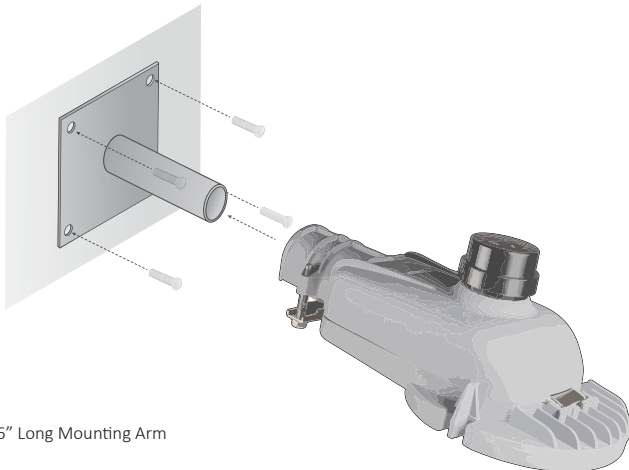

6" Long Mounting Arm

Installation hardware provided by installer

Specification drawings for mounting accessories are available at  
<https://leotek.com/lighting-library/>





ComfortView™

ComfortView™ streetlights utilize a new approach to address glare for neighborhood streets. Now neighborhoods can be beautifully lit with more visual comfort than first-generation LED luminaires while maintaining safety and energy efficiency. As with our other GreenCobra® LED Streetlights, ComfortView™ is built with durable high-strength materials and reliable components, and is backed by our 10-Year Warranty and 30 years of experience building LED lighting products.



ComfortGuide®

Arieta® ComfortGuide™ is perfectly suited for parking lots, campuses, office complexes, streets and public parks, as well as many other applications. ComfortGuide™ utilizes a new approach to address glare produced by traditional lighting. First-generation LED optical systems incorporate a single optical lens over the LED.



Eseta™

Eseta's subtly distinctive form harmonizes with architecture without altering the building aesthetic. Eseta™ features ultra-high efficiency LED lighting greater than 100 lumens/watt, emergency battery system, two targeted distributions, innovative glare control, and motion sensor compatibility. Cold-weather rated for temperature range rating of -4°F to 140°F (-20°C to +60°C). An appealing and easy choice for retrofit applications.



LEOTEK Electronics USA LLC, located in California's Silicon Valley, is celebrating over thirty years as an LED lighting manufacturer, and is a leading supplier of LED streetlights worldwide. Globally recognized as a pioneer in light-emitting diode technology, and with millions of LED products installed worldwide, the company has a historical legacy of proven performance. LEOTEK offers innovative LED lighting products for applications encompassing traffic, transit, street, and area lighting. LEOTEK street and area lighting products are assembled in the USA.

1955 Lundy Ave., San Jose, CA 95131  408.380.1788