

DT Series Extended Life 12" Traffic Signal Module Incandescent Look Arrow



Leading the LED Industry Since 1992

With over 7,000,000 units installed globally

Superior Performance and Reliability

- Special extended life LEDs (LM-80/TM-21)
- Special purpose-built extended life power supply
- Intertek ETL verified
- Meets and/or exceeds all ITE standards ITE VTC SH LED Arrow Signal Supplement dated July 1, 2007
- Patented innovative optical technology
- Wider viewing angle and enhanced uniformity
- Overmolded electrical connectors provide fully-weatherized seal
- Excellent moisture and dust resistance
- Utilizes constant current source to maintain consistent light output
- 15-year limited full performance warranty



Mechanical Dimensions [in(mm)]

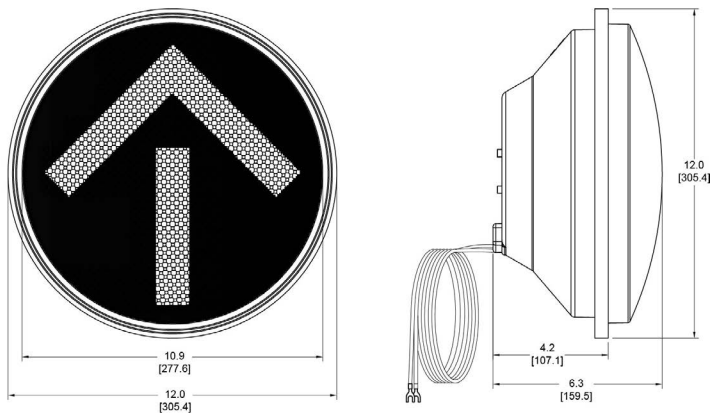

12 inch



DT Series Extended Life 12" Traffic Signal Module Incandescent Look Arrow

Model Specifications and Ordering Options

Operating Temperature: -40°F to 165°F (-40°C to 74°C)	Turn-On/Turn-Off Time: < 75msec
Operating Voltage: 80 - 135Vac	Turn-Off Voltage: > 35Vac
Power Factor: > 0.90	Total Harmonic Distortion (THD): < 20%

DT	Model Number and Color	Wattage Drawn	Voltage	Dominant Wavelength	Maintained Intensity (cd) Min.	Standard
	12 inch arrow					
	TSL-12RA-DT-A1 	6	80-135Vac	626	58.4	ITE 2007/ETL
	TSL-12YA-DT-A1 	10	80-135Vac	589	145.6	ITE 2007/ETL
	TSL-12GA-DT-A1 	6.8	80-135Vac	500	76.0	ITE 2007/ETL

Notes:

1 Tinted lens standard, clear lens optional. When ordering clear lens, please add "-CLR" to model number. Both tinted and clear lens are Intertek ETL Verified.

Standard Conformance

- FCC Compliant for Electrical Noise
- MIL-STD-810F Moisture Resistant
- MIL-STD-883 Mechanical Vibration
- NEMA TS2 Section 2.1.8, Transient Voltage Protection over 2000V
- IEC 1000-4-5, 3KV, 2 ohm source impedance
- ANSI/IEEE C62.41-2002; IEC 61000-4-12, 6KV, 200A, 100KHz ring wave

ITE VTCSH Compliance - LED Arrow Signal Supplement – July 1, 2007

• Conditioning	ITE 6.4.2	• Luminous Intensity	ITE 6.4.4.1-4
• Mechanical Vibration	ITE 6.4.3.1	• Chromaticity	ITE 6.4.4.6
• Temperature Cycling	ITE 6.4.3.2	• Current Consumption	ITE 6.4.6.1