

# VersaTEK Medium LED Floodlight Series

## VTMFL Specification Data Sheet

### Luminaire Data

- Weight** 22.7 lbs [10.3 kg] ('SF', 'SFH', 'SFC' mount)  
 24.8 lbs [11.3 kg] ('TR' mount)  
 22.2 lbs [10.1 kg] ('YK' mount)  
 26.4 lbs [12.0 kg] ('AWM' mount)  
 28.9 lbs [13.1 kg] ('AWMSC' mount)  
 22.0 lbs [10.0 kg] ('ASPM' mount)  
 22.7 lbs [10.3 kg] ('ARPM' mount)



(\*VTMFL medium housing w/ 'SF' slipfitter mount & optional 'PCR7CR' shown)

### Ordering Information

Sample Catalog No. VTMFL-144A-MV-40K7-N66-DB1-CF-P4-SFH-PCR7CR-NB01P-TB-WL1-SP2-SF120

Product	LED Code	Voltage	Color Temp CRI	Optical Distribution	Finish*	Performance Code	Mounting Options
VTMFL VersaTEK Medium Flood	144A 144 LEDs Gen-A	MV 120-277V	27K7 2700K, 70CRI	N66 NEMA 6Hx6V Flood	BK Black	P1	SF <sup>2</sup> Slipfitter w/ Wire Leads (in UL splice compartment)
		HV 347-480V	30K7 3000K, 70CRI 40K7 4000K, 70CRI 50K7 5000K, 70CRI	S33 NEMA 3Hx3V Spot NSP Narrow Spot	DB1 Dark Bronze (RAL8019) WH White GY Gray	P2 P3 P4 P5 P6 P7 P8 P9 P10 P11 P12	SFH <sup>3</sup> Slipfitter w/ S/O Cord Exiting Housing Bottom (3-wire S/O cord, 16AWG, 4' exit length) SFC <sup>3</sup> Slipfitter w/ S/O Cord Exiting Center of Fitter (3-wire S/O cord, 16AWG, 4' exit length)
			30K8 <sup>1</sup> 3000K, 80CRI 40K8 <sup>1</sup> 4000K, 80CRI 50K8 <sup>1</sup> 5000K, 80CRI	RN Rectangular Narrow RM Rectangular Medium RW Rectangular Wide WG Wall Grazer	CF Coastal Finish <small>*Consult factory for custom finish options, pricing &amp; leadtimes.</small>		TR <sup>3</sup> Trunnion Mount (3-wire S/O cord, 16AWG, 4' exit length) YK <sup>3</sup> Yoke Mount (3-wire S/O cord, 16AWG, 4' exit length) AWM Adjustable Wall Mount (compatible w/ 3" & 4" square/octagonal recessed J-boxes) AWMSC Adjustable Wall Mount w/ Surface Conduit J-Box ASPM Universal Square Pole Adjustable Arm Mount ARPM Universal Round Pole Adjustable Arm Mount

(see pages 3-4 for details)

Driver* & Control Options (*0-10V drivers are standard)	General Options
D4I <sup>4,8</sup> DALI D4i Driver	AIM45 <sup>10</sup> Slipfitter Factory Pre-aimed at 45°
TLR4U <sup>4,5,8</sup> DALI 4-PIN Twist Lock Receptacle (upper housing receptacle location)	SS Slipfitter Set Screw (replaces standard slipfitter set bolts)
TLR4L <sup>4,5,8</sup> DALI 4-PIN Twist Lock Receptacle (lower driver door receptacle location)	TFL Tamper free latch (driver electrical door)
NB01P <sup>6</sup> LEOlink 7-PIN Smart Controller (120-277V)	TB <sup>2</sup> 3-position Terminal Block
PCR7CR <sup>4,6</sup> ANSI 7-wire Control Ready Receptacle	SP2 <sup>11</sup> 20kV/10kA Extreme Surge, Fail-to-On
SC Shorting Cap (factory installed)	LSSP2 20kV/10kA Extreme Surge, Fail-to-Off
LLPC <sup>7</sup> Long Life Photocontrol	WL Wattage Label, ANSI C136.15-2015 compliant
PS <sup>8</sup> Field Adjustable Performance Selector	WL1 Wattage Label, ANSI C136.15-2020 compliant
PND1 <sup>9</sup> Part Night Dimming V1	DSC Optional Driver Door Safety Cable
PND2 <sup>9</sup> Part Night Dimming V2	PWRD Power Door Option (tool-free removable door w/ serviceable electrical items)
PND3 <sup>9</sup> Part Night Dimming V3	SFXXX <sup>12</sup> Single Fuse ('XXX' = specify voltage 120, 277, 347V)
	DFXXX <sup>12</sup> Double Fuse ('XXX' = specify voltage 208, 240, 480V)
	5WSO <sup>13</sup> 5-wire S/O Cord (16AWG, 4' length w/ dimming leads)
	SOXXYY <sup>14</sup> Special S/O AWG & Cord Length in Feet ('XX' = specify AWG 12, 14 or 16) ('YY' = specify S/O cord length 06, 08, 10, 15, 25)

General Accessories*
<b>Shield Accessories</b>
TBS-VTM Top, Bottom Shield
LRS-VTM Left, Right Side Shield
4SS-VTM 4-sided Shield
BDS-VTM Barn Door Shield
VS-VTM Poly Vandal Shield
WG-VTM Wire Guard
BSK Bird Deterrent Spider Kit
<b>Controls Accessories</b>
NB01PSS <sup>15</sup> NB01P Ships Separately
LLPCMV Long Life Photocontrol MV
LLPCHV Long Life Photocontrol HV

\*Accessories are ordered & shipped separately, not to be included in the luminaire's catalog number. (requires field installation)

1. 80CRI option only available in 3000K, 4000K & 5000K CCTs and may have longer leadtimes (contact factory).  
 2. 'TB' Terminal Block is not available for use with the 'SF' Slipfitter mounting option. 3. Mounting option includes 16AWG 3-wire S/O cord w/ a 4' exit length & last 6" of insulation removed.  
 4. For full 100% D4i DALI functionality a 'PCR7CR', 'TLR4U' or 'TLR4L' must be selected w/ 'D4I' DALI driver option. DALI compatible node or sensor (by others).  
 5. 'TLR4U' & 'TLR4L' twist lock receptacle option requires 'D4I' DALI driver option to be selected.  
 6. 'NB01P' requires 'LPCR7CR' option, only available in 'MV' 120-277V (contact factory for 'HV' 347-480V availability). 'NB01P' is a cellular based NEMA 7-PIN Smart Controller, 10-YR data (200MB), RenAI subscription included.  
 7. 'LLPC' requires 'PCR7CR' option to be selected (does not ship installed, ships included w/ luminaire).  
 8. 'PS' Performance Selector enables field adjustable light output dimming control from specified Performance Code, not compatible with DALI driver option (see pg.5 for details).  
 9. 'PND' options only available w/ 'MV' 120-277V (contact factory for 'HV' 347-480V availability). 10. Slipfitter options 'SF', 'SFC', 'SFH' ship pre-aimed at 45° from the factory if 'AIM45' is specified.  
 11. 10kV/5kA surge, fail-to-on is included standard ('SP1'). 12. For single or double fusing, 'XXX' must specify required voltage.  
 13. '5WSO' only available with 'SFC', 'SFH', 'TR' & 'YK' mounting options. Not available w/ 'PCR7CR', 'PS', 'PND', 'D4I', 'TLR4U', 'TLR4L' options.  
 14. 'SOXXYY' option, 'XX' & 'YY' must specify S/O cord AWG & length (only available w/ SO cord mounting options). 15. Denotes 'NB01P' Smart Controllers will ship bulk or master pack and ships separately from the luminaire.



### Luminaire Specifications

#### Housing & Construction

Rugged grade A360 die-cast aluminum housing, glass lens frame and door frame (<0.6% copper). Housing includes integral heatsink fins and (3) pass-thru convective cooling slots between the LED array heatsink and driver compartment for enhanced cooling and maximum thermal management to maximize LED platform and electrical component lifetime. Electrical access door provides access to electrical components via two corrosion resistant stainless-steel tool-free latches (tamper free latch option 'TFL' is available). Door can be removed without the use of tools. Electrical door comes standard with an integral VersaKICK 'kickstand' to quickly and easily prop open the the door to allow for frustration free installation or maintenance. Optional 'PWRD' Power Door mounts all serviceable electrical components on the door with tool-free removal for easy field maintenance or replacement. Internal bubble level standard for leveling during install. All exposed hardware and fasteners are corrosion resistant stainless-steel. Entire luminaire is IP66 rated.

#### Flood & Wall Mounting Options

Trunnion 'TR' and yoke 'YK' mounting options are constructed of formed steel. (3) adjustable slipfitter mounting options 'SF', 'SFC' and 'SFH' are rugged A360 die-cast aluminum and includes safety thru-bolt detail if required. Slipfitter 'AIM45' options ships factory preset to a tilt of 45°. Self-centering design feature also assists with leveling during installation. Designed to install to 1-5/8", 2-3/8" and 3" O.D. tenons (by others). Available in (3) wiring configurations ('SF' includes available wire leads accessed via an integral UL recognized splice compartment, 'SFC' and 'SFH' options include S/O cord exiting the center of the slipfitter or housing bottom). Standard S/O cord configurations ('TR', 'YK', 'SFH', 'SFC') are 16AWG 3-wire with an exit length of 4' and last 6" of weatherproof covering removed. Additional wire gauges and lengths available (see 'Ordering Information' for details). Adjustable wall mount 'AWM' options mount to recessed 3" and 4" square or octagonal recessed J-boxes (by others). Surface conduit wall mount option 'AWMSC' includes (4) 3/4" NPT thru-wire taps with plugs. All wall mount options include an integral bubble level for ease of installation. Universal/retrofit adjustable square 'ASPM', adjustable round 'ARPM' arm mount options can accept bolt spacings from 2.29" to 5.25" and are designed for quick and easy single person installation. Mounting provisions meet 3G vibration per ANSI C136.31-2010 Normal Application, Bridge & Overpass.

### Color Specifications

Order Code	Color	RAL #	Pantone Equivalent
<b>GY</b>	Gray	7040	429C
<b>BK</b>	Black	9004	BLACK 6C
<b>DB1</b>	Dark Bronze	8019	412
<b>WH</b>	White	9003	11-0601

#### Light Emitting Diodes

Hi-flux/Hi-power white 5050 LED optics produce a minimum of 90% of initial lumen output at 95,000 hours of life (at 25°C) and 3535 LED optics at 118,000 hours of life based on IES TM-21. LEDs are tested in accordance with IES LM-80 testing procedures. IES TM-21 lumen maintenance life projection is based on 6X the duration of the LED's IES LM-80 performance data (estimates beyond 6X are extrapolated per TM-21). LED correlated color temperature options of 2700K, 3000K, 4000K, or 5000K @ 70CRI or 80CRI (2700K is 70CRI only). LEDs are 100% mercury and lead free.

#### Optical Systems

All Micro-lens optical systems are fully sealed to maintain an IP66 rating. All-purpose 5050 LED flood optics include a NEMA 6x6 Wide Flood 'N66' and NEMA 3x3 Spot 'S33'. Performance 3535 LED flood optics include a Narrow Spot 'NSP', Rectangular Narrow 'RN', Rectangular Medium 'RM', Rectangular Wide 'RW', Wall Grazer 'WG'. Please refer to 'Performance Data' on pages 3-4 for specific beam & optical performance details. An IK10 impact resistant glass lens is standard for ease of routine cleaning and improved light loss dirt depreciation over the life of the luminaire. Multiple glare and light trespass shielding options and accessories are available (see 'Ordering Information' for details).

#### Photometry

Luminaires photometrics are tested by certified independent testing laboratories in accordance with IES LM-79 testing procedures.

#### Electrical

Rated life of electrical components is 100,000 hours. Standard 0-10V dimmable drivers use an isolated power supply with 6kV integral surge standard. Power supply features a minimum power factor of 0.90 and <20% Total Harmonic Distortion (THD). EMC meets or exceeds FCC CFR Part 15. Optional DALI D4i certified LED drivers also available, which complies with IEC 62386 and ANSI C137.4 and DiiA. Optional 3-position terminal block accommodates 6 to 16AWG wire. Standard surge protection (10kV/5kA Surge, Fail-to-On) complies with IEEE/ANSI C62.41 and ANSI C136.2-2015. Optional 'SP2' and 'LSSP2' provides (20kV/10kA) extreme level surge protection.

#### Field Adjustability

Optional Performance Selector 'PS' is an integral 8-step fixed position dial allowing field adjustable lumen and wattage dimming control for added project and design versatility to meet installation specific requirements. The specified Performance Code provides the maximum lumen output. Only compatible with VersaTEK's standard 0-10V drivers. Not compatible with DALI driver option.

#### General Control Options

ANSI C136.41 7-wire controls ready photocontrol receptacle 'PCR7CR' option available for use with LEOLink nodes or by others. Receptacle has a tool-less rotatable base with a positive lock to not allow over-rotation and possible damage to the receptacle. Optional DALI D4i and Part Night Dimming driver configurations are also available for added controllability and design flexibility. DALI compatible 'TLR4U' and 'TLR4L' 4-PIN twist lock receptacle options available (wireless DALI nodes or DALI sensors are by others).

#### LEOLink Intelligent Lighting System

ANSI C136.41 7-wire smart wireless controllers allow real-time monitoring and asset management of luminaires with 'NB01P' wireless control nodes installed. RenAI cloud-based application receives system data while applying specific AI models for fault isolation and the resolution of voltage health, outages, knockdowns, energy usage, LED faults and more. Allows for full remote management of deployed install base, including the ability to store and execute customer specific schedules and performance parameters. System communicates via standard 4G/5G IoT networks with a cellular data plan and and RenAI subscription.

#### Finish

Housing receives a fade and abrasion resistant textured polyester powder coat finish with 3.0 mil nominal thickness. Finish tested to withstand 5000 hours in salt spray exposure per ASTM B117 and Coastal Finish per ASTM G85. Finish tested 500 hours in UV exposure per ASTM G154 and meets ASTM D523 gloss retention.

#### Listings/Ratings/Labels

Luminaires are UL listed for use in wet locations in the United States and Canada and are rated IP66. Luminaires are qualified to operate at ambient temperatures of -40°C to 50°C. (-40°F to 122°F)

#### Government Procurement Compliance

BAA - Buy America(n) Act: All LEOTEK luminaires qualify as a "Domestic End Product" per the Buy American Act as governed by FAR.

BABA - Build America Buy America: All LEOTEK luminaires are compliant with the requirements for BABA as outlined per the Federal Highway Administration (FHWA).

#### Quality Control

Every luminaire is assembled in the USA and is performance tested before and after a 2-hour burn-in period.

#### Warranty

10-year limited warranty is standard on luminaire and components. See LEOTEK.com for warranty details, terms and conditions.

#### Standards

Luminaire complies with:  
ANSI: C136.2, C136.3, C136.10, C136.13, C136.15, C136.22, C136.31, C136.35, C136.37, C136.41, C62.41, C78.377, C82.77  
Other: FCC 47 CFR, IEC 60598, ROHS II, UL 1449, UL 1598

**Performance Data\*** (5050LED All-purpose Flood Optics, 70CRI\*, 25°C ambient... \*for 80CRI option use a 0.91 multiplier)

Normal tolerance +/- 10% due to factors that include distribution type, LED bin variance and ambient temperatures.

Perf. Code	System Wattage (W)	Optic	Beam Angle		Field Angle		27K7 (2700K CCT, 70CRI)			30K7 (3000K CCT, 70CRI)			40K7 (4000K CCT, 70CRI)			50K7 (5000K CCT, 70CRI)			LLD @ 25°C		
			°H (50%)	°V (50%)	°H (10%)	°V (10%)	Lumens	LPW	Max CD	Lumens	LPW	Max CD	Lumens	LPW	Max CD	Lumens	LPW	Max CD	50K Hours	75K Hours	100K Hours
P1	57 27K7, 30K7	N66	98.6	92.5	114.7	108.7	8,850	155.3	3,688	9,470	166.1	3,947	10,500	178.0	4,375	10,500	178.0	4,375	0.979	0.972	0.965
	59 40K7, 50K7	S33	24.9	25.1	38.9	39.6	8,399	147.4	27,518	8,989	157.7	29,447	9,963	168.9	32,643	9,963	168.9	32,643			
P2	59 27K7, 30K7	N66	98.6	92.5	114.7	108.7	9,375	158.9	3,907	10,032	170.0	4,180	13,472	175.0	5,614	13,472	175.0	5,614	0.979	0.972	0.965
	77 40K7, 50K7	S33	24.9	25.1	38.9	39.6	8,896	150.8	29,147	9,519	161.3	31,191	12,783	166.0	41,883	12,783	166.0	41,883			
P3	77 27K7, 30K7	N66	98.6	92.5	114.7	108.7	12,029	156.2	5,012	12,874	167.2	5,364	16,442	174.9	6,851	16,442	174.9	6,851	0.979	0.972	0.965
	94 40K7, 50K7	S33	24.9	25.1	38.9	39.6	11,414	148.2	37,397	12,216	158.6	40,019	15,602	166.0	51,116	15,602	166.0	51,116			
P4	94 27K7, 30K7	N66	98.6	92.5	114.7	108.7	14,681	156.2	6,117	15,710	167.1	6,546	19,535	176.0	8,140	19,535	176.0	8,140	0.979	0.972	0.965
	111 40K7, 50K7	S33	24.9	25.1	38.9	39.6	13,931	148.2	45,642	14,909	158.6	48,842	18,537	167.0	60,732	18,537	167.0	60,732			
P5	111 27K7, 30K7	N66	98.6	92.5	114.7	108.7	17,442	157.1	7,268	18,666	168.2	7,778	22,399	177.8	9,333	22,399	177.8	9,333	0.979	0.972	0.965
	126 40K7, 50K7	S33	24.9	25.1	38.9	39.6	16,551	149.1	54,227	17,712	159.6	58,029	21,254	168.7	69,634	21,254	168.7	69,634			
P6	126 27K7, 30K7	N66	98.6	92.5	114.7	108.7	20,000	158.7	8,334	21,401	169.8	8,918	25,197	176.2	10,499	25,197	176.2	10,499	0.979	0.972	0.965
	143 40K7, 50K7	S33	24.9	25.1	38.9	39.6	18,977	150.6	62,176	20,307	161.2	66,535	23,909	167.2	78,333	23,909	167.2	78,333			
P7	143 27K7, 30K7	N66	98.6	92.5	114.7	108.7	22,497	157.3	9,375	24,076	168.4	10,032	27,929	174.6	11,638	27,929	174.6	11,638	0.979	0.972	0.965
	160 40K7, 50K7	S33	24.9	25.1	38.9	39.6	21,348	149.3	69,943	22,845	159.8	74,847	26,502	165.6	86,828	26,502	165.6	86,828			
P8	160 27K7, 30K7	N66	98.6	92.5	114.7	108.7	24,938	155.9	10,391	26,686	166.8	11,120	30,596	171.9	12,749	30,596	171.9	12,749	0.942	0.919	0.896
	178 40K7, 50K7	S33	24.9	25.1	38.9	39.6	23,664	147.9	77,528	25,323	158.3	82,964	29,032	163.1	95,119	29,032	163.1	95,119			
P9	178 27K7, 30K7	N66	98.6	92.5	114.7	108.7	27,319	153.5	11,383	29,233	164.2	12,181	33,174	163.4	13,823	33,174	163.4	13,823	0.942	0.919	0.896
	203 40K7, 50K7	S33	24.9	25.1	38.9	39.6	25,923	145.6	84,931	27,741	155.8	90,886	31,478	155.1	103,132	31,478	155.1	103,132			
P10	203 27K7, 30K7	N66	98.6	92.5	114.7	108.7	29,621	145.9	12,342	31,697	156.1	13,208	35,844	163.7	14,936	35,844	163.7	14,936	0.942	0.919	0.896
	219 40K7, 50K7	S33	24.9	25.1	38.9	39.6	28,107	138.5	92,087	30,077	148.2	98,543	34,012	155.3	111,435	34,012	155.3	111,435			
P11	219 27K7, 30K7	N66	98.6	92.5	114.7	108.7	32,005	146.1	13,336	34,249	156.4	14,271	39,758	164.3	16,566	39,758	164.3	16,566	0.942	0.919	0.896
	242 40K7, 50K7	S33	24.9	25.1	38.9	39.6	30,370	138.7	99,500	32,499	148.4	106,476	37,726	155.9	123,602	37,726	155.9	123,602			
P12	242 27K7, 30K7	N66	98.6	92.5	114.7	108.7	35,499	146.7	14,792	37,989	157.0	15,829	42,305	162.7	17,628	42,305	162.7	17,628	0.942	0.919	0.896
	260 40K7, 50K7	S33	24.9	25.1	38.9	39.6	33,685	139.2	110,364	36,047	149.0	118,102	40,143	154.4	131,522	40,143	154.4	131,522			

**Performance Data\*** (3535LED Performance Flood Optics, 70CRI\*, 25°C ambient... \*for 80CRI option use a 0.91 multiplier)  
 Normal tolerance +/- 10% due to factors that include distribution type, LED bin variance and ambient temperatures.

Perf. Code	System Wattage (W)	Optic	Beam Angle		Field Angle		27K7 (2700K CCT, 70CRI)			30K7 (3000K CCT, 70CRI)			40K7 (4000K CCT, 70CRI)			50K7 (5000K CCT, 70CRI)			LLD @ 25°C		
			°H (50%)	°V (50%)	°H (10%)	°V (10%)	Lumens	LPW	Max CD	Lumens	LPW	Max CD	Lumens	LPW	Max CD	Lumens	LPW	Max CD	50K Hours	75K Hours	100K Hours
			P1	74	NSP	15.6	15.9	33	33.2	10,138	137.0	74,741	11,081	149.7	81,694	11,788	159.3	86,908	11,788	159.3	86,908
RN	66.4	20.2			97.5	41	9,620	130.0	17,503	10,515	142.1	19,132	11,186	151.2	20,353	11,186	151.2	20,353			
RM	77.3	32.7			125.3	56.4	9,691	131.0	10,056	10,592	143.1	10,992	11,268	152.3	11,694	11,268	152.3	11,694			
RW	86.3	49.4			132.8	107.1	9,213	124.5	7,090	10,070	136.1	7,750	10,713	144.8	8,245	10,713	144.8	8,245			
WG	100.5	32.9			144.6	94.5	9,217	124.6	7,668	10,074	136.1	8,382	10,717	144.8	8,917	10,717	144.8	8,917			
P2	91	NSP	15.6	15.9	33	33.2	12,421	129.5	91,574	13,576	149.2	100,092	14,443	158.7	106,481	14,443	158.7	106,481	0.963	0.940	0.916
		RN	66.4	20.2	97.5	41	11,787	129.5	21,445	12,883	141.6	23,440	13,706	150.6	24,936	13,706	150.6	24,936			
		RM	77.3	32.7	125.3	56.4	11,873	130.5	12,321	12,978	142.6	13,467	13,806	151.7	14,327	13,806	151.7	14,327			
		RW	86.3	49.4	132.8	107.1	11,288	124.0	8,687	12,338	135.6	9,495	13,126	144.2	10,102	13,126	144.2	10,102			
		WG	100.5	32.9	144.6	94.5	11,293	124.1	9,395	12,343	135.6	10,269	13,131	144.3	10,925	13,131	144.3	10,925			
P3	100	NSP	15.6	15.9	33	33.2	13,581	135.8	100,124	14,844	148.4	109,438	15,791	157.9	116,423	15,791	157.9	116,423	0.963	0.940	0.916
		RN	66.4	20.2	97.5	41	12,887	128.9	23,448	14,086	140.9	25,629	14,985	149.9	27,265	14,985	149.9	27,265			
		RM	77.3	32.7	125.3	56.4	12,982	129.8	13,472	14,190	141.9	14,725	15,095	151.0	15,665	15,095	151.0	15,665			
		RW	86.3	49.4	132.8	107.1	12,342	123.4	9,498	13,490	134.9	10,382	14,351	143.5	11,045	14,351	143.5	11,045			
		WG	100.5	32.9	144.6	94.5	12,347	123.5	10,272	13,495	135.0	11,228	14,357	143.6	11,945	14,357	143.6	11,945			
P4	110	NSP	15.6	15.9	33	33.2	15,376	139.8	113,363	16,807	152.8	123,908	17,880	162.5	131,817	17,880	162.5	131,817	0.963	0.940	0.916
		RN	66.4	20.2	97.5	41	14,591	132.6	26,548	15,949	145.0	29,018	16,967	154.2	30,870	16,967	154.2	30,870			
		RM	77.3	32.7	125.3	56.4	14,698	133.6	15,253	16,066	146.1	16,672	17,091	155.4	17,736	17,091	155.4	17,736			
		RW	86.3	49.4	132.8	107.1	13,974	127.0	10,754	15,274	138.9	11,755	16,249	147.7	12,505	16,249	147.7	12,505			
		WG	100.5	32.9	144.6	94.5	13,979	127.1	11,631	15,280	138.9	12,713	16,255	147.8	13,524	16,255	147.8	13,524			
P5	123	NSP	15.6	15.9	33	33.2	16,983	138.1	125,205	18,562	150.9	136,852	19,747	160.5	145,588	19,747	160.5	145,588	0.963	0.940	0.916
		RN	66.4	20.2	97.5	41	16,116	131.0	29,321	17,615	143.2	32,049	18,739	152.3	34,095	18,739	152.3	34,095			
		RM	77.3	32.7	125.3	56.4	16,234	132.0	16,846	17,744	144.3	18,414	18,877	153.5	19,589	18,877	153.5	19,589			
		RW	86.3	49.4	132.8	107.1	15,434	125.5	11,878	16,869	137.1	12,983	17,946	145.9	13,811	17,946	145.9	13,811			
		WG	100.5	32.9	144.6	94.5	15,440	125.5	12,846	16,876	137.2	14,041	17,953	146.0	14,937	17,953	146.0	14,937			
P6	136	NSP	15.6	15.9	33	33.2	18,589	136.7	137,048	20,318	149.4	149,796	21,615	158.9	159,358	21,615	158.9	159,358	0.963	0.940	0.916
		RN	66.4	20.2	97.5	41	17,640	129.7	32,095	19,281	141.8	35,080	20,511	150.8	37,319	20,511	150.8	37,319			
		RM	77.3	32.7	125.3	56.4	17,769	130.7	18,440	19,422	142.8	20,155	20,662	151.9	21,442	20,662	151.9	21,442			
		RW	86.3	49.4	132.8	107.1	16,893	124.2	13,001	18,465	135.8	14,211	19,644	144.4	15,118	19,644	144.4	15,118			
		WG	100.5	32.9	144.6	94.5	16,900	124.3	14,061	18,472	135.8	15,369	19,651	144.5	16,350	19,651	144.5	16,350			
P7	150	NSP	15.6	15.9	33	33.2	20,195	134.6	148,890	22,074	147.2	162,741	23,483	156.6	173,128	23,483	156.6	173,128	0.963	0.940	0.916
		RN	66.4	20.2	97.5	41	19,164	127.8	34,868	20,947	139.6	38,111	22,284	148.6	40,544	22,284	148.6	40,544			
		RM	77.3	32.7	125.3	56.4	19,305	128.7	20,033	21,101	140.7	21,897	22,448	149.7	23,295	22,448	149.7	23,295			
		RW	86.3	49.4	132.8	107.1	18,353	122.4	14,125	20,061	133.7	15,439	21,341	142.3	16,424	21,341	142.3	16,424			
		WG	100.5	32.9	144.6	94.5	18,361	122.4	15,276	20,069	133.8	16,697	21,350	142.3	17,762	21,350	142.3	17,762			
P8	162	NSP	15.6	15.9	33	33.2	21,802	134.6	160,733	23,830	147.1	175,685	25,351	156.5	186,898	25,351	156.5	186,898	0.963	0.940	0.916
		RN	66.4	20.2	97.5	41	20,688	127.7	37,641	22,613	139.6	41,143	24,056	148.5	43,769	24,056	148.5	43,769			
		RM	77.3	32.7	125.3	56.4	20,840	128.6	21,627	22,779	140.6	23,638	24,233	149.6	25,147	24,233	149.6	25,147			
		RW	86.3	49.4	132.8	107.1	19,813	122.3	15,248	21,656	133.7	16,667	23,038	142.2	17,730	23,038	142.2	17,730			
		WG	100.5	32.9	144.6	94.5	19,821	122.4	16,491	21,665	133.7	18,025	23,048	142.3	19,175	23,048	142.3	19,175			
P9	176	NSP	15.6	15.9	33	33.2	23,408	133.0	172,575	25,585	145.4	188,629	27,218	154.6	200,669	27,218	154.6	200,669	0.963	0.940	0.916
		RN	66.4	20.2	97.5	41	22,213	126.2	40,415	24,279	137.9	44,174	25,829	146.8	46,994	25,829	146.8	46,994			
		RM	77.3	32.7	125.3	56.4	22,376	127.1	23,220	24,457	139.0	25,380	26,018	147.8	27,000	26,018	147.8	27,000			
		RW	86.3	49.4	132.8	107.1	21,273	120.9	16,372	23,252	132.1	17,895	24,736	140.5	19,037	24,736	140.5	19,037			
		WG	100.5	32.9	144.6	94.5	21,281	120.9	17,706	23,261	132.2	19,353	24,746	140.6	20,588	24,746	140.6	20,588			
P10	193	NSP	15.6	15.9	33	33.2	24,541	127.2	180,930	26,824	139.0	197,760	28,536	147.9	210,383	28,536	147.9	210,383	0.963	0.940	0.916
		RN	66.4	20.2	97.5	41	23,288	120.7	42,371	25,454	131.9	46,313	27,079	140.3	49,269	27,079	140.3	49,269			
		RM	77.3	32.7	125.3	56.4	23,459	121.5	24,344	25,641	132.9	26,609	27,278	141.3	28,307	27,278	141.3	28,307			
		RW	86.3	49.4	132.8	107.1	22,303	115.6	17,164	24,377	126.3	18,761	25,933	134.4	19,958	25,933	134.4	19,958			
		WG	100.5	32.9	144.6	94.5	22,312	115.6	18,563	24,387	126.4	20,290	25,944	134.4	21,585	25,944	134.4	21,585			
P11	210	NSP	15.6	15.9	33	33.2	25,977	123.7	191,517	28,394	135.2	209,333	30,206	143.8	222,694	30,206	143.8	222,694	0.963	0.940	0.916
		RN	66.4	20.2	97.5	41	24,651	117.4	44,851	26,944	128.3	49,023	28,664	136.5	52,152	28,664	136.5	52,152			
		RM	77.3	32.7	125.3	56.4	24,832	118.2	25,769	27,142	129.2	28,166	28,874	137.5	29,964	28,874	137.5	29,964			
		RW	86.3	49.4	132.8	107.1	23,608	112.4	18,169	25,804	122.9	19,859	27,451	130.7	21,126	27,451	130.7	21,126			
		WG	100.5	32.9	144.6	94.5	23,617	112.5	19,649	25,814	122.9	21,477	27,462	130.8	22,848	27,462	130.8	22,848			
P12	220	NSP	15.6	15.9	33	33.2	27,449	124.8	202,366	30,002	136.4	221,190	31,917	145.7	235,309	31,917	145.1	235,309	0.963	0.940	0.916
		RN	66.4	20.2	97.5	41	26,047	118.4	47,391												

### Optional Field Adjustable Performance Selector 'PS' (*'PS' is only compatible with standard 0-10V drivers, not compatible w/ optional DALI drivers*)

The optional Performance Selector is an integral dial that allows for field adjustable lumen/wattage dimming control for added design versatility. Normal tolerance +/- 8%.

#### 2700K, 3000K (5050LED Optics - N66, S33)\*

PS Position	Lumen Output %	P1	P2	P3	P4	P5	P6	P7	P8	P9	P10	P11	P12
		Wattage (W)											
8	100%	57	59	77	94	111	126	143	160	178	203	219	242
7	90%	50	52	68	83	98	112	127	142	158	180	194	214
6	80%	45	47	61	75	88	100	114	127	142	161	174	192
5	70%	39	41	53	65	76	87	98	110	122	140	151	166
4	60%	34	35	46	56	67	76	86	96	107	122	132	145
3	50%	28	29	38	47	55	62	71	79	88	100	108	120
2	40%	22	23	30	37	44	50	56	63	70	80	86	95
1	30%	17	17	23	28	33	37	42	47	53	60	65	71

\*For 80CRI option use an additional 0.91 lumen multiplier.

#### 4000K, 5000K (5050LED Optics - N66, S33)\*

PS Position	Lumen Output %	P1	P2	P3	P4	P5	P6	P7	P8	P9	P10	P11	P12
		Wattage (W)											
8	100%	59	77	94	111	126	143	160	178	203	219	242	260
7	90%	52	68	83	98	112	127	142	158	180	194	214	230
6	80%	47	61	75	88	100	114	127	142	161	174	192	207
5	70%	41	53	65	76	87	98	110	122	140	151	166	179
4	60%	35	46	56	67	76	86	96	107	122	132	145	156
3	50%	29	38	47	55	62	71	79	88	100	108	120	129
2	40%	23	30	37	44	50	56	63	70	80	86	95	102
1	30%	17	23	28	33	37	42	47	53	60	65	71	77

\*For 80CRI option use an additional 0.91 lumen multiplier.

#### 2700K, 3000K, 4000K, 5000K (3535LED Optics - NSP, RN, RM, RW, WG)\*

PS Position	Lumen Output %	P1	P2	P3	P4	P5	P6	P7	P8	P9	P10	P11	P12
		Wattage (W)											
8	100%	74	91	100	110	123	136	150	162	176	193	210	220
7	90%	65	81	89	97	109	120	133	143	156	171	186	195
6	80%	59	72	80	87	98	108	119	129	140	153	167	175
5	70%	51	63	69	76	85	94	103	111	121	133	144	151
4	60%	44	55	60	66	74	82	90	97	106	116	126	132
3	50%	37	45	50	54	61	67	74	80	87	96	104	109
2	40%	29	36	39	43	48	54	59	64	69	76	83	87
1	30%	22	27	30	32	36	40	44	48	52	57	62	65

\*For 80CRI option use an additional 0.91 lumen multiplier.

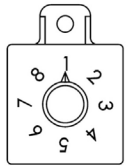

Optional Field Adjustable Performance Selector 'PS' Dial

### IES TM-21 LED Lumen Maintenance (*\*values italicized are per LM-80 data that is extrapolated beyond the TM-21 6X standard*)

Reported lumen maintenance life projections are based on 6X the duration of the LED's IES LM-80 tested performance data in accordance per IES TM-21 guidelines.

5050LED Optics P1 to P7	IES TM-21 LED Lumen Maintenance					
	0 Hrs	25,000 Hrs	50,000 Hrs	60,000 Hrs	*75,000 Hrs	*100,000 Hrs
VTM @ 25°C Ambient	100.00%	98.60%	97.89%	97.61%	<i>97.19%</i>	<i>96.49%</i>
VTM @ 50°C Ambient	100.00%	96.80%	94.60%	93.74%	<i>92.46%</i>	<i>90.37%</i>

5050LED Optics P8 to P12	IES TM-21 LED Lumen Maintenance					
	0 Hrs	25,000 Hrs	50,000 Hrs	60,000 Hrs	*75,000 Hrs	*100,000 Hrs
VTM @ 25°C Ambient	100.00%	96.65%	94.23%	93.27%	<i>91.86%</i>	<i>89.56%</i>
VTM @ 50°C Ambient	100.00%	95.09%	91.92%	90.68%	<i>88.86%</i>	<i>85.89%</i>

3535LED Optics	IES TM-21 LED Lumen Maintenance					
	0 Hrs	25,000 Hrs	50,000 Hrs	60,000 Hrs	*75,000 Hrs	*100,000 Hrs
VTM @ 25°C Ambient	100.00%	98.75%	96.32%	95.37%	<i>93.95%</i>	<i>91.64%</i>
VTM @ 50°C Ambient	100.00%	97.98%	94.73%	93.46%	<i>91.59%</i>	<i>88.55%</i>

**Optical Isofootcandle Plots** ('P12' Performance Code, 4000K/5000K, 70CRI, 20' Mounting Height MH, Grid Scale = MH or 20' as shown)

Complete non-shielded & shielded photometric IES files are available for download at [www.LEOTEK.com](http://www.LEOTEK.com) or can be found in AGI32's Photometric Instabase.

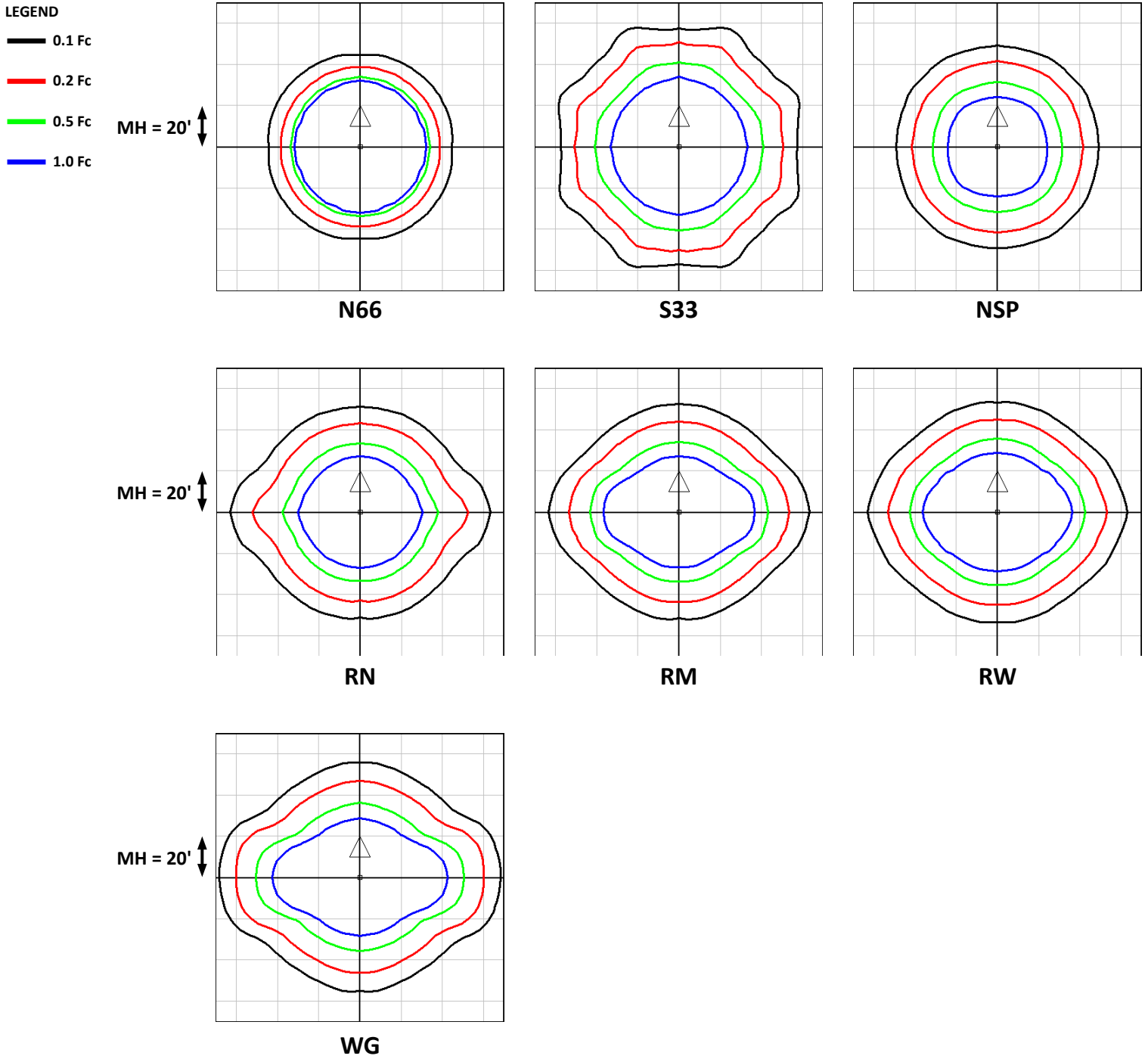

### Mounting Option Details & Dimensional Information

#### 'SF' Slipfitter Mount #1\*

(available wire leads in UL splice compartment)  
(shown w/ optional 'PCR7CR')

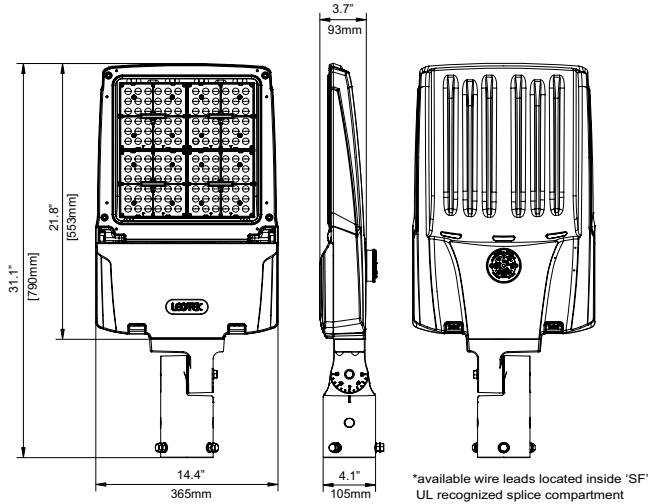

#### 'SFC' Slipfitter #2\*

(w/ 3-wire S/O Cord Center Fitter Exit)

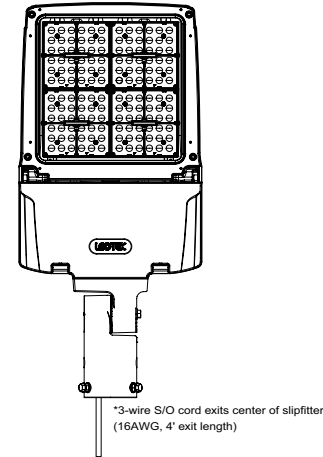

#### 'SFH' Slipfitter #3\*

(w/ 3-wire S/O Cord Bottom Housing Exit)



#### 'TR' Trunnion Mount\*

(shown w/ optional 'PCR7CR')

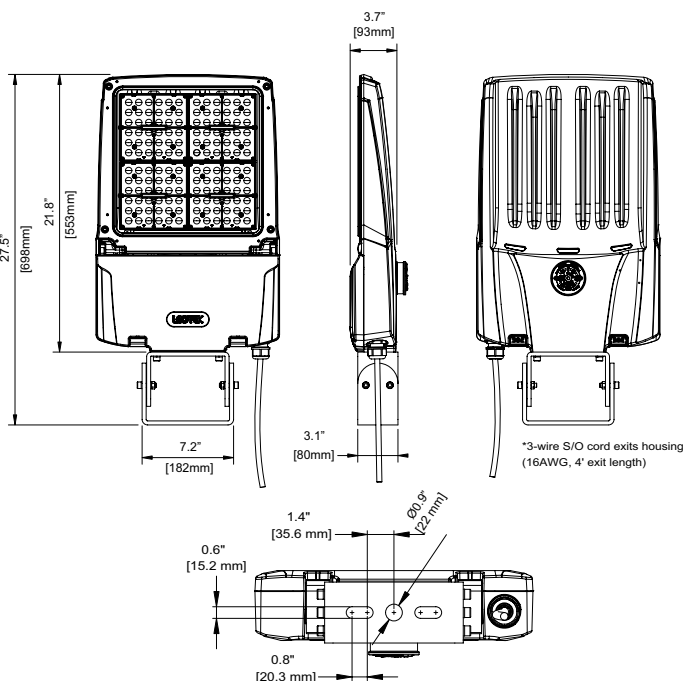

#### 'YK' Yoke Mount\*

(shown w/ optional 'PCR7CR')

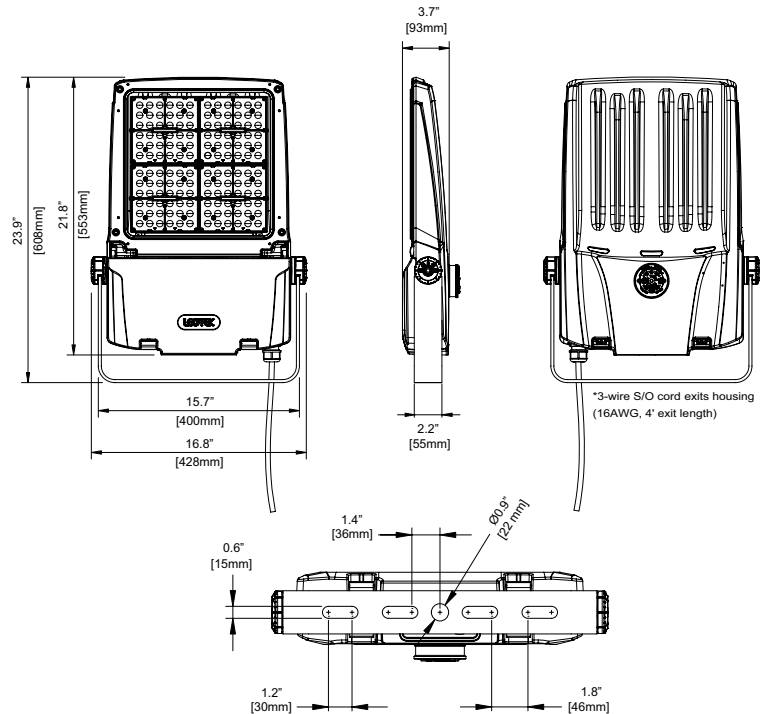

## Mounting Option Details & Dimensional Information

### 'AWM' Adjustable Wall Mount\*

(mounts to recessed J-box, shown w/ optional 'PCR7CR')

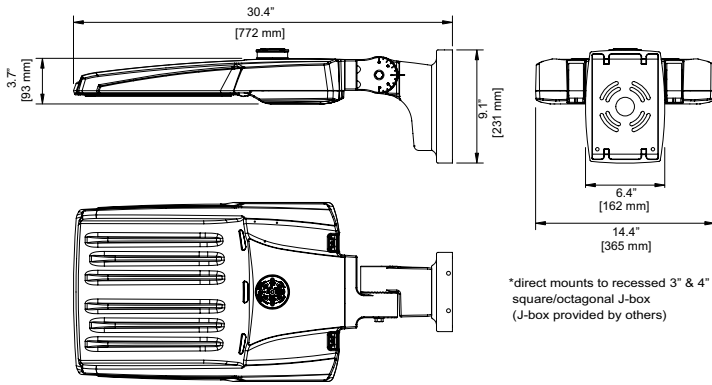

### 'AWMSC' Adjustable Wall Mount Surface Conduit\*

(includes surface mount 3/4" conduit J-box, shown w/ optional 'PCR7CR')

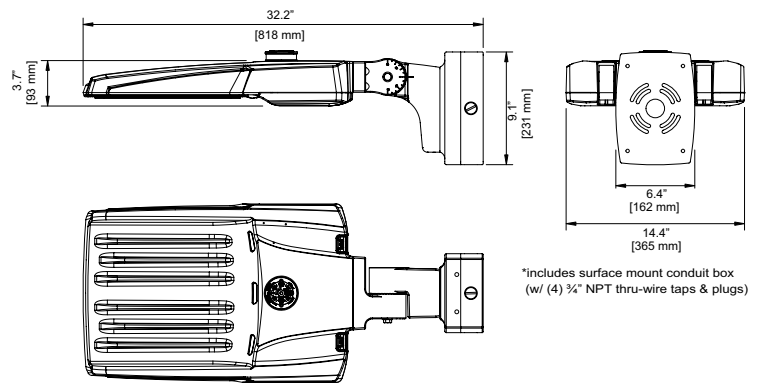

### 'ASPM' Square & 'ARPM' Adjustable Round Pole Arm Mount\*

(quick mount arm can retrofit up to 5.25" max. bolt spacing w/ no drilling required)

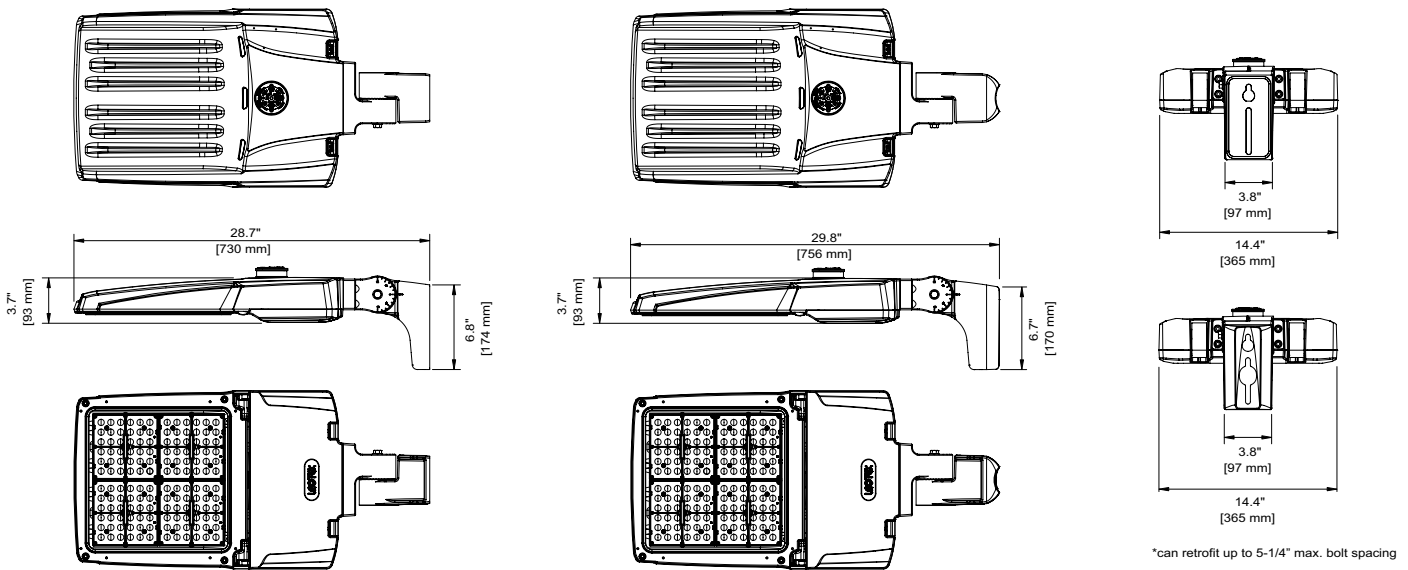

### Key Additional Miscellaneous Product Features & Design Details

#### Integral Tool-Free Access Design

Tool-free electrical access & removable hinged door w/ fixed open door prop design for ease of installation or maintenance  
(compatible w/ most lineman safety gloves)



#### Slipfitter w/ UL Splice Box

'SF' Slipfitter w/ integral UL recognized splice compartment  
(w/ available wire lead access & WAGOs for ease of installation)



#### Self-Centering Design

Slipfitter options are designed with a self-centering & leveling design feature  
(compatible w/ 1-5/8", 2-3/8" & 3" O.D. tenons)

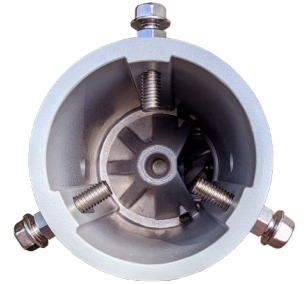

#### 3-Position Terminal Block 'TB' Option

For ease of maintenance & increased safety, improved wire management & robust product life cycle operation  
(includes line, neutral & ground, accommodates 6 to 16AWG wire)

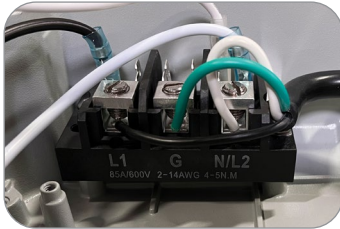

#### Performance Selector 'PS' Option

Allows for quick & easy field adjustment of wattage, lumen output and reduced SKU complexity  
(fixed position dial ensures correct output setting)

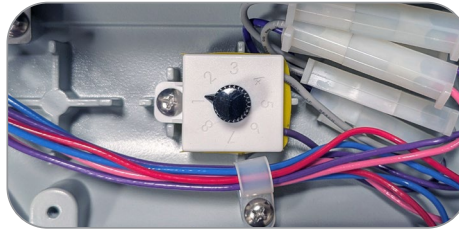

#### Integral VersaKick

VersaKick 'kickstand' props open the door during installation or maintenance  
(allows for 'frustration free' ease of access)



#### Pass-Thru Convective Cooling

(3) integral cooling slots allows ambient air to flow freely thru the luminaire for enhanced thermal management  
(maximizes lifetime of electrical components & lumen maintenance)



#### Tool-Free Removable Power Door Option 'PWRD'

All serviceable electrical components are mounted to a tool-free removable Power Door that can be removed in less than 15 seconds to safely service on the ground or replace in seconds  
(undo MOLEX connectors, push two spring clips inward to unlock door, slide the door forward & lift to remove)

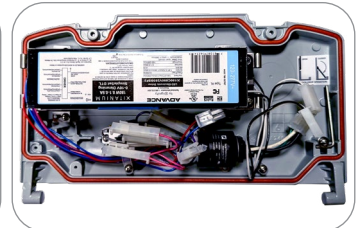
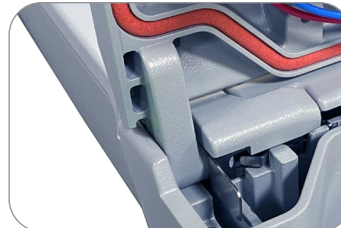
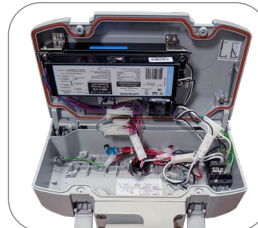

'4SS-VTM'  
4-Sided Shield



'TBS-VTM'  
Top or Bottom Shield



'LRS-VTM'  
Left or Right Side Shield



'BDS-VTM'  
Barn Door Shield



'WG-VTM'  
Wire Guard



'VS-VTM'  
Poly Vandal Shield

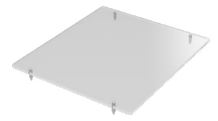

### LEOLink ILS™ Intelligent Lighting System for Tomorrow's Smart & Sustainable Cities

#### Smart...Scalable...Effortless

LEOLink ILS is the next evolution in street lighting, integrating AI and IoT to transform a city's traditional outdoor lighting infrastructure into a smart, adaptive network. It empowers municipalities and utilities with real-time control, predictive maintenance, and rapid scalability, all with unmatched simplicity.

Integrating LEOTEK's AI-driven centralized management platform (LEOLink RenAI) with intelligent streetlight controllers, LEOLink ILS provides 24x7 visibility into the status and performance of streetlights enabling efficient energy use, real-time fault detection, and predictive maintenance across city-wide lighting networks. Easy "plug-and-play" deployment and scalability support users in achieving operational excellence, public safety, and long-term sustainability. With LEOLink ILS, cities are creating the backbone of a future-ready smart city.

### Key Functions

#### Centralized, Remote Management

Gain complete control of your city's smart lighting infrastructure from a single, intuitive platform.

#### Instant Response to Anomalies

Automatically identify and respond to abnormal lighting behavior in real-time.

#### AI-Powered Predictive Maintenance

Detect and address faults before they occur, minimizing downtime and maintenance costs.

#### Actionable Insights Through Data Visualization

Monitor asset performance and energy trends with clear, interactive dashboards and reports.

#### Energy Efficiency & Cost Savings

Optimize energy usage with intelligent scheduling and dimming, reducing operational expenses.

### LEOLink NB01 Plus Smart Controller Key Features & Benefits

The smartest fit for 7-PIN NEMA fixtures. Engineered to deliver seamless performance, trusted security, and plug-and-play simplicity, all in one powerful, next-generation controller.



\*LEOLink 'NB01P' Smart Controller

Model	Form Factor	Fixture Compatibility	Connectivity	Power Source	Typical Use Case
NB01 Plus	NEMA 7-pin	Most ANSI C136.41-compliant fixtures	NB-IoT / LTE CAT-M	Powered via NEMA socket	Retrofit or upgrade existing fixtures



#### Self-Monitoring & Fault Detection

NB01P continuously monitors the luminaire's operational status, identifying power outages, failures, and abnormal energy patterns for fast diagnostics and improved maintenance efficiency.



#### AI-Driven Adaptive Dimming

Participates with LEOLink RenAI to enable intelligent dimming strategies, including human-centric lighting adjustments based on real-time traffic, weather, and pedestrian activity.



#### Ultra-High Connectivity

Dual-mode cellular communication using the world's most reliable and secure carriers ensures a 99.5% connection success rate, delivering reliable continuous data transmission even in challenging environments.



#### Predictive Maintenance & Analytics

Advanced failure analysis and predictive diagnostics move cities from reactive to preventative maintenance strategies that reduce downtime and operational costs.



#### Built-In Surge Protection

Advanced surge protection against lightning and voltage spikes safeguards critical streetlight infrastructure.

### LEOLink RenAI Central Management System Key Features & Benefits

An AI-powered cloud-based streetlight Central Management System (CMS), LEOLink RenAI is at the core of the LEOLink Intelligent Lighting System (ILS). Unlike traditional CMS platforms, LEOLink RenAI, leverages a native AI foundation to transform streetlighting into a dynamic, adaptive, and self-optimizing system by analyzing real-time and historical data. Designed to meet the complex demands of modern roadway infrastructure, LEOLink RenAI helps municipalities improve energy efficiency, reduce operational costs, and improve public safety across city-wide lighting networks.



#### LiSA (LEOTEK intelligent Service Advisor)

LiSA, our AI-powered assistant, is available 24/7 to streamline operations, quickly answering questions, generating charts and tables, and assisting with troubleshooting to lighten your team's workload.



#### Fault Detection & Notification

Monitor streetlight health and status in real time to detect and receive instant fault alerts.



#### Asset Management

Collect and track roadway infrastructure asset information such as streetlight fixtures, poles and controllers. to drive operational efficiencies across from field maintenance to life cycle management.



#### Energy Consumption Management

Track usage, identify trends, and forecast energy needs for optimal efficiency.



#### Remote Control

Remotely switch lights ON/OFF and adjust brightness via an intuitive user interface.



#### Data Analysis & Reporting

Access historical insights, visualize data, and generate reports for informed decision-making.



#### Scheduled Dimming

Automatically adjusts brightness levels based on ambient light and pre-set schedules.

**Part-Night Dimming Specifications**

**Description**

Part-Night Dimming (PND) option enables significant energy savings by automatically dimming the luminaire during early morning hours when infrequent use is expected. Factory programmed dimming profiles automatically take into account seasonal changes based on geographical location by continuously monitoring the nighttime midpoint. PND does not provide power on/off control which is provided by external controls (example: time clock or a photocontrol using 'PCR7CR' option). Dimming profile of PND option is not field adjustable.

**Operation**

Based on the PND profile that is selected, the luminaire dims to the corresponding % power for the corresponding length of time (based on the nighttime mid-point) as shown below. Mid-point is continuously recalculated in the luminaire by monitoring the average length of time between when the light turns on (power on) and turns off (power off) over the previous two days. In effect, this functionality will take two days to initialize after installation before any dimming will occur. Power interruptions are ignored and do not affect the determination of mid-point. Three factory programmed PND profiles are available for selection:

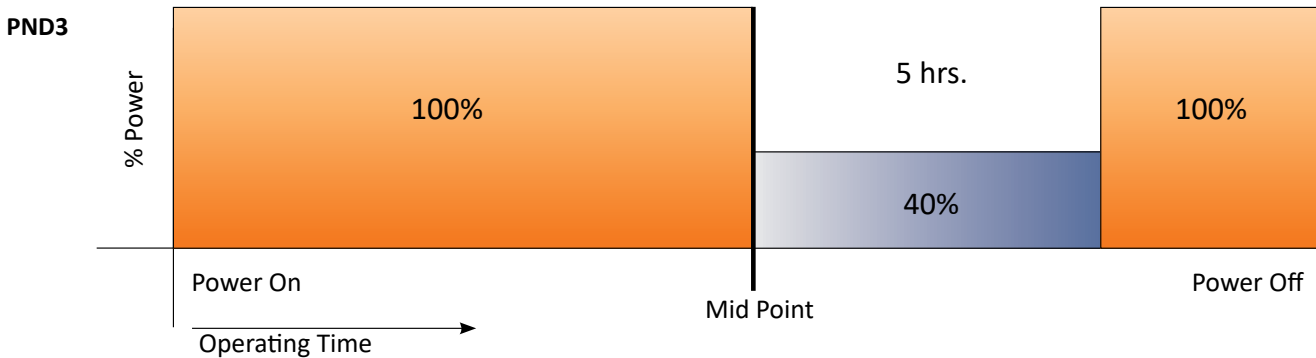
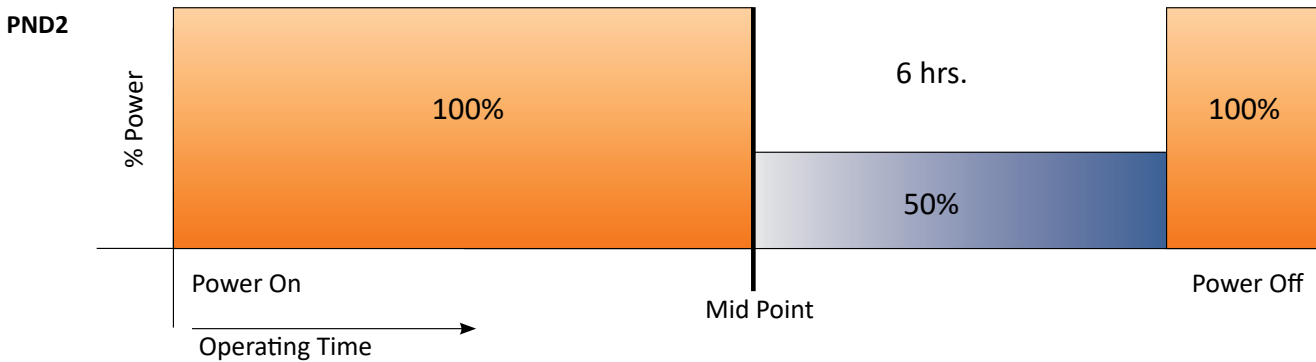
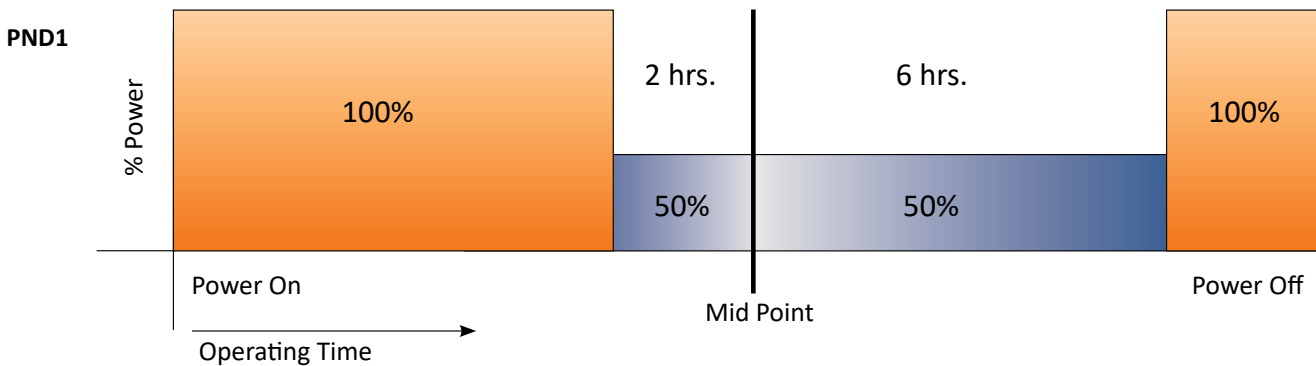

### VersaTEK Medium LED Flood - Luminaire EPA Values

(\*Includes luminaire and mounting options shown. Secondary tenons, brackets or other accessories are not included in the EPA data.)

Luminaire Quantity & Orientation		Effective Projected Area (EPA ft <sup>2</sup> )								
		Single	2 @ 90	2 @ 180	3 @ 90	3 @ 120	4 @ 90	2 Side by Side	3 Side by Side	4 Side by Side
Mounting Option	Tilt									
SF Slip Fitter	0°	0.99	1.43	1.97	2.42	2.11	2.42	0.89	1.34	1.78
	10°	0.99	1.61	1.97	2.59	2.46	2.59	1.25	1.87	2.50
	20°	1.03	2.02	1.97	3.00	3.19	3.00	2.06	3.09	4.13
	30°	1.42	2.41	1.97	3.39	3.94	3.39	2.84	4.26	5.69
SFC Slip Fitter Center	40°	1.78	2.76	1.97	3.75	4.64	3.75	3.55	5.33	7.10
	45°	1.94	2.92	1.97	3.91	4.96	3.91	3.87	5.81	7.75
	50°	2.08	3.07	2.08	4.05	5.25	4.05	4.16	6.24	8.32
	60°	2.33	3.31	2.33	4.30	5.74	4.30	4.66	6.99	9.32
SFH Slip Fitter Housing	70°	2.51	3.49	2.51	4.48	6.11	4.48	5.02	7.52	10.03
	80°	2.63	3.61	2.63	4.60	6.35	4.60	5.25	7.88	10.50
	90°	2.67	3.65	2.67	4.64	6.44	4.64	5.34	8.01	10.68
	0°	0.70	1.19	1.41	1.89	1.82	1.89	0.97	1.45	1.93
YK Yoke Mount	10°	0.71	1.37	1.42	2.08	2.18	2.08	1.32	1.98	2.63
	20°	1.04	1.78	1.48	2.52	2.91	2.52	2.08	3.12	4.17
	30°	1.41	2.17	1.52	2.93	3.65	2.93	2.82	4.23	5.64
	40°	1.74	2.51	1.74	3.28	4.31	3.28	3.48	5.22	6.96
	45°	1.89	2.66	1.89	3.43	4.61	3.43	3.78	5.66	7.55
	50°	2.02	2.80	2.02	3.57	4.87	3.57	4.05	6.07	8.09
	60°	2.25	3.02	2.25	3.80	5.32	3.80	4.49	6.74	8.99
	70°	2.41	3.18	2.41	3.96	5.65	3.96	4.81	7.22	9.63
	80°	2.51	3.29	2.51	4.07	5.86	4.07	5.01	7.52	10.03
	90°	2.54	3.32	2.54	4.11	5.93	4.11	5.08	7.62	10.16
TR Trunnion Mount	0°	0.81	1.26	1.63	2.07	1.91	2.07	0.89	1.34	1.78
	15°	0.84	1.65	1.63	2.47	2.64	2.47	1.68	2.52	3.36
	30°	1.46	2.27	1.63	3.09	3.83	3.09	2.92	4.38	5.83
	45°	1.99	2.80	1.99	3.62	4.87	3.62	3.98	5.97	7.96
	60°	2.39	3.21	2.39	4.02	5.68	4.02	4.79	7.18	9.58
	75°	2.65	3.46	2.65	4.28	6.20	4.28	5.30	7.95	10.59
ASPM & ARPM Adjustable Square & Round Pole Arm Mount	90°	2.74	3.56	2.74	4.37	6.40	4.37	5.49	8.23	10.97
	0°	0.88	1.44	1.76	2.33	2.25	2.33	1.13	1.69	2.25
	10°	0.88	1.64	1.76	2.53	2.62	2.53	1.52	2.28	3.05
	20°	1.17	2.05	1.76	2.93	3.35	2.93	2.34	3.51	4.68
	30°	1.56	2.44	1.76	3.32	4.11	3.32	3.12	4.68	6.24
	40°	1.91	2.80	1.91	3.68	4.80	3.68	3.83	5.74	7.66
	45°	2.08	2.96	2.08	3.84	5.12	3.84	4.15	6.23	8.30
	50°	2.22	3.10	2.22	3.98	5.41	3.98	4.44	6.66	8.89
	60°	2.47	3.35	2.47	4.23	5.91	4.23	4.94	7.40	9.87
	70°	2.65	3.53	2.65	4.41	6.27	4.41	5.29	7.94	10.59
80°	2.76	3.65	2.76	4.53	6.52	4.53	5.53	8.29	11.06	
90°	2.80	3.69	2.80	4.57	6.61	4.57	5.61	8.41	11.21	

### Adjustable Square & Round Pole Arm Mount Drilling Dimensions for New Construction

(for additional details, please consult online installation instructions)

