

VersaTEK Medium LED OFF-Roadway Series VTMOR Specification Data Sheet

Luminaire Data

- Weight** 20.3 lbs [9.2 kg] ('SF', 'SFH', 'SFC' slipfitter version)
18.5 lbs [8.4 kg] ('SPM' square pole arm mount)
19.4 lbs [8.8 kg] ('RPM' mount)
19.6 lbs [8.9 kg] ('MAF' mast arm fitter mount)
19.6 lbs [8.9 kg] ('ASPM' adjustable square pole arm mount)

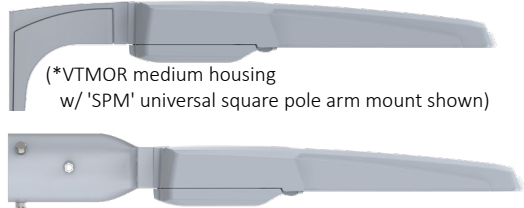

(*VTMOR medium housing w/ 'SPM' universal square pole arm mount shown)

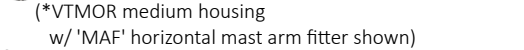

(*VTMOR medium housing w/ 'MAF' horizontal mast arm fitter shown)



(*VTMOR medium housing w/ 'SF' slipfitter mount & optional 'PCR7CR' shown)



Ordering Information

Sample Catalog No. VTMOR-144A-MV-50K7-WR-GY-P4-SFC-PCR7CR-NB01-TB-SP2-WL1-PWRD-SF277

Product	LED Code	Voltage	Color Temp CRI	Optical Distribution	Finish*	Performance Code	Mounting Options
VTMOR VersaTEK Medium OFF-Roadway	144A 144 LEDs Gen-A	MV 120-277V HV 347-480V	27K7 2700K, 70CRI 30K7 3000K, 70CRI 40K7 4000K, 70CRI 50K7 5000K, 70CRI 30K8 ¹ 3000K, 80CRI 40K8 ¹ 4000K, 80CRI 50K8 ¹ 5000K, 80CRI	NR Narrow Roadway	BK Black	P1	SF ² Slipfitter w/ Wire Leads (in UL splice compartment) SFH ³ Slipfitter w/ S/O Cord Exiting Housing Bottom (3-wire S/O cord, 16AWG, 4' exit length) SFC ³ Slipfitter w/ S/O Cord Exiting Center of Fitter (3-wire S/O cord, 16AWG, 4' exit length) SPM Universal Square Pole Arm Mount RPM Universal Round Pole Arm Mount MAF Horizontal Mast Arm Fitter (compatible w/ 1-5/8", 2-3/8" and 3" O.D. tenons) ASPM Universal Square Pole Adjustable Arm Mount ARPM Universal Round Pole Adjustable Arm Mount
				MR Medium Roadway	DB1 Dark Bronze (RAL8019)	P2	
				WR Wide Roadway	WH White	P3	
				T2R Type-2R	GY Gray	P4	
				T2F Type-2F	CF Coastal Finish	P5	
				T2F Type-2F		P6	
				T3R Type-3R	*Consult factory for custom finish options, pricing & leadtimes.	P7	
				T3F Type-3F		P8	
				T4R Type-4R	(see pages 3-4 for details)	P9	
				T4F Type-4F		P10	
T5 Type-5	P11						
ORR Optics Rotated Right	P12						
ORL Optics Rotated Left	P13						
	P14						

Driver* & Control Options (*0-10V drivers are standard)	General Options
D41 ^{4,8} DALI D4i Driver	AIM45 ¹³ Slipfitter Factory Pre-aimed at 45°
TLR4U ^{4,5,8} DALI 4-PIN Twist Lock Receptacle (upper housing receptacle location)	SS Slipfitter Set Screw (replaces standard slipfitter set bolts)
TLR4L ^{4,5,8} DALI 4-PIN Twist Lock Receptacle (lower driver door receptacle location)	TFL Tamper free latch (driver electrical door)
NB01P ⁶ LEOlink 7-PIN Smart Controller (120-277V)	TB ² 3-position Terminal Block
PCR7CR ^{4,11} ANSI 7-wire Control Ready Receptacle	SP2 ¹⁴ 20kV/10kA Extreme Surge, Fail-to-On
SC Shorting Cap (factory installed)	LSSP2 20kV/10kA Extreme Surge, Fail-to-Off
LLPC ⁷ Long Life Photocontrol	WL Wattage Label, ANSI C136.15-2015 compliant
PS ⁹ Field Adjustable Performance Selector	WL1 Wattage Label, ANSI C136.15-2020 compliant
PND1 ⁹ Part Night Dimming V1	DSC Optional Driver Door Safety Cable
PND2 ⁹ Part Night Dimming V2	PWRD Power Door Option (tool-free removable door w/ serviceable electrical items)
PND3 ⁹ Part Night Dimming V3	SFXXX ¹⁵ Single Fuse ('XXX' = specify 120, 277, 347V)
MSL3 ^{10,11} Motion Sensor w/ L3 Lens	DFXXX ¹⁵ Double Fuse ('XXX' = specify 208, 240, 480V)
MSL7 ^{10,11} Motion Sensor w/ L7 Lens	SWSO ¹⁶ 5-wire S/O Cord (16AWG, 4' length w/ dimming leads)
MSL3P ^{10,12} Motion Sensor w/ L3 Lens w/ PCR7	SOXXX ¹⁷ Special S/O AWG & Cord Length in Feet ('XX' = specify AWG 12, 14 or 16) ('YY' = specify S/O cord length 06, 08, 10, 15, 25)
MSL7P ^{10,12} Motion Sensor w/ L7 Lens w/ PCR7	BLS Enhanced Back Light Shield (factory installed)
	VHS 80 Degree Cutoff Shield (factory installed)
	FSS Front Side Shield (factory installed)
	CSS Cul-de-sac Shield (factory installed)

General Accessories*
Shield Accessories
TBS-VTM Top, Bottom Shield
LRS-VTM Left, Right Side Shield
4SS-VTM 4-sided Shield
BDS-VTM Barn Door Shield
VS-VTM Poly Vandal Shield
WG-VTM Wire Guard
BLS-VTM Enhanced Backlight Shield (snap-on)
VHS-VTM ¹⁸ 80-Degree Cutoff Shield (snap-on)
FSS-VTM Front Side Shield (snap-on)
CSS-VTM Cul-de-sac Shield (snap-on)
BSK Bird Deterrent Spider Kit
Controls Accessories
NB01PSS ¹⁹ NB01P Ships Separately
LLPCMV Long Life Photocontrol MV
LLPCHV Long Life Photocontrol HV
FSIR100 MS Configuration Tool
*Accessories are ordered & shipped separately, not to be included in the luminaire's catalog number. (requires field installation)

1. 80CRI option only available in 3000K, 4000K & 5000K CCTs and may have longer leadtimes (contact factory).
2. 'TB' Terminal Block is not available for use with the 'SF' Slipfitter mounting option. 3. 'SFH' & 'SFC' options include 16AWG 3-wire S/O cord w/ a 4' exit length & last 6" of insulation removed.
4. For full 100% D4i DALI functionality a 'PCR7CR', 'TLR4U' or 'TLR4L' must be selected w/ 'D4i' DALI driver option. DALI compatible node or sensor (by others). 5. 'TLR4U' & 'TLR4L' twist lock receptacle options requires 'D4i' driver option to be selected.
6. 'NB01P' requires 'LPCR7CR' option, only available in 'MV' 120-277V (contact factory for 'HV' 347-480V availability). 'NB01P' is a cellular based NEMA 7-PIN Smart Controller, 10-YR data (200MB), RenAI subscription included.
7. 'LLPC' requires 'PCR7CR' option to be selected (does not ship installed, included w/ luminaire). 8. 'PS' Performance Selector enables field adjustable light output dimming control from specified Performance Code, not compatible with DALI (see pg.5 for details).
9. 'PND' options only available w/ 'MV' 120-277V (contact factory for 'HV' 347-480V availability). 10. Motion Sensor options only available w/ 'SPM', 'RPM' and 'MAF' horizontal mounting options.
11. 'MSL3', 'MSL7' motion sensors require secondary controls for ON/OFF capability (ex. time clock or 0-10V by others). Contact factory for Motion Sensor availability w/ 'PCR7CR' control ready receptacle for use with wireless 7-PIN control node (by others).
12. 'MSL3P', 'MSL7P' motion sensors includes a PCR7 photocontrol for use with a twist lock photocontrol for ON/OFF capability (for use with our 'LLPC' or photocontrol by others, PINS 6 & 7 are not wired for controls, not compatible w/ wireless nodes).
13. Slipfitter options ship pre-aimed at 45° from the factory if specified. 14. 10kV/5kA surge, fail-to-on is included standard ('SP1'). 15. For single or double fusing, 'XXX' must specify required voltage.
16. 'SWSO' only available with 'SFC' & 'SFH' options. Not available w/ 'PCR7CR', 'PS', 'PND', 'D4i', 'TLR4U', 'TLR4L' options.
17. 'SOXXX' option, 'XX' & 'YY' must specify S/O cord AWG & length (only available w/ SO cord mounting options).
18. 'VHS-VTM' 80-Degree Cutoff shield is not available for use with the 'T5' Type-5 optical distribution.
19. Denotes 'NB01P' Smart Controllers will ship bulk or master pack and ships separately from the luminaire.
© 2026 LEOTEK Electronics USA LLC.



Luminaire Specifications

Housing & Construction

Rugged grade A360 die-cast aluminum housing, and door frame (<0.6% copper). Housing includes integral heatsink fins and (3) pass-thru convective cooling slots between the LED array heatsink and driver compartment for enhanced cooling and maximum thermal management to maximize LED platform and electrical component lifetime. Electrical access door provides access to electrical components via two corrosion resistant stainless-steel tool-free latches (tamper free latch option 'TFL' is available). Door can be removed without the use of tools. Electrical door comes standard with an integral VersaKICK 'kickstand' to quickly and easily prop open the the door to allow for frustration free installation or maintenance. Optional 'PWRD' Power Door mounts all serviceable electrical components on the door with tool-free removal for easy field maintenance or replacement. Internal bubble level standard for leveling during install. All exposed hardware and fasteners are corrosion resistant stainless-steel. Entire luminaire is IP66 rated.

Light Emitting Diodes

Hi-flux/Hi-power white LEDs produce a minimum of 90% of initial lumen output at 95,000 hours of life based on IES TM-21 (at 25°C). LEDs are tested in accordance with IES LM-80 testing procedures. IES TM-21 lumen maintenance life projection is based on 6X the duration of the LED's IES LM-80 performance data (estimates beyond 6X are extrapolated per TM-21). LED correlated color temperature options of 2700K, 3000K, 4000K, or 5000K @ 70CRI or 80CRI (2700K is 70CRI only). LEDs are 100% mercury and lead free.

Site & Area and Wall Mounting Options

All site & area and wall mounting options are constructed of rugged A360 die-cast aluminum. Universal/retrofit square pole 'SPM', round pole 'RPM' and adjustable square 'ASPM', adjustable round 'ARPM' arm mount options can accept bolt spacings from 2.29" to 5.25" and are designed for quick and easy single person installation. Horizontal mast arm fitter 'MAF' is designed to install to horizontal 1-5/8", 2-3/8" and 3" O.D. tenons. Fixed 'WM' and adjustable 'AWM' wall mount options mount to recessed 3" or 4" square or octagonal recessed J-boxes (by others). Surface conduit wall mount options 'WMSC' and 'AWMSC' includes (4) 3/4" NPT thru-wire taps with plugs. All wall mount options include an integral bubble level for ease of installation. Mounting provisions meet 3G vibration per ANSI C136.31-2010 Normal Application, Bridge & Overpass.

Color Specifications

Order Code	Color	RAL #	Pantone Equivalent
GY	Gray	7040	429C
BK	Black	9004	BLACK 6C
DB1	Dark Bronze	8019	412
WH	White	9003	11-0601

OFF-Roadway Mounting Options

All OFF-Roadway adjustable slipfitter mounting options 'SF', 'SFC' and 'SFH' are rugged A360 die-cast aluminum and includes safety thru-bolt detail if required. Slipfitter 'AIM45' options ships factory preset to a tilt of 45°. Self-centering design feature also assists with leveling during installation. Designed to install to 1-5/8", 2-3/8" and 3" O.D. tenons (by others). Available in (3) wiring configurations ('SF' includes available leads accessed via an integral UL recognized splice compartment, 'SFC' and 'SFH' options include S/O cord exiting the center of the slipfitter or housing bottom). Standard S/O cord configurations ('SFH', 'SFC') are 16AWG 3-wire with an exit length of 4' and last 6" of weatherproof covering removed. Additional wire gauges and lengths available (see 'Ordering Information' for details). Mounting provisions meet 3G vibration per ANSI C136.31-2010 Normal Application, Bridge & Overpass.

Optical Systems

All Micro-lens optical systems are fully sealed to maintain an IP66 rating. All Site & Area and OFF-Roadway optical distributions produce 0% total lumens above 90° when installed horizontally (BUG Rating, U=0). Auto Front Row (AFR) optics are designed to enhance light levels at dealership's site perimeter while minimizing wattage and backlight. Multiple glare and light trespass shielding options and accessories are available (see 'Ordering Information' for details).

Photometry

Luminaires photometrics are tested by certified independent testing laboratories in accordance with IES LM-79 testing procedures.

Field Adjustability

Optional Performance Selector 'PS' is an integral 8-step fixed position dial allowing field adjustable lumen and wattage dimming control for added project and design versatility to meet installation specific requirements. The specified Performance Code provides the maximum lumen output. Only compatible with VersaTEK's standard 0-10V drivers. Not compatible with DALI driver option.

General Control Options

ANSI C136.41 7-wire controls ready photocontrol receptacle 'PCR7CR' option available for use with LEOLink nodes or by others. Receptacle has a tool-less rotatable base with a positive lock to not allow over-rotation and possible damage to the receptacle. Optional DALI D4i and Part Night Dimming driver configurations are also available for added controllability and design flexibility. DALI compatible 'TLR4U' and 'TLR4L' 4-PIN twist lock receptacle options available (wireless DALI nodes or DALI sensors are by others).

LEOLink Intelligent Lighting System

ANSI C136.41 7-wire smart wireless controllers allow real-time monitoring and asset management of luminaires with 'NB01P' wireless control nodes installed. RenAI cloud-based application receives system data while applying specific AI models for fault isolation and the resolution of voltage health, outages, knockdowns, energy usage, LED faults and more. Allows for full remote management of deployed install base, including the ability to store and execute customer specific schedules and performance parameters. System communicates via standard 4G/5G IoT networks with a cellular data plan and RenAI subscription.

Electrical

Rated life of electrical components is 100,000 hours. Standard 0-10V dimmable drivers use an isolated power supply with 6kV integral surge standard. Power supply features a minimum power factor of 0.90 and <20% Total Harmonic Distortion (THD). EMC meets or exceeds FCC CFR Part 15. Optional DALI D4i certified LED drivers also available, which complies with IEC 62386 and ANSI C137.4 and DiiA. Optional 3-position terminal block accommodates 6 to 16AWG wire. Standard surge protection (10kV/5kA Surge, Fail-to-On) complies with IEEE/ANSI C62.41 and ANSI C136.2-2015. Optional 'SP2' and 'LSSP2' provides (20kV/10kA) extreme level surge protection.

Finish

Housing receives a fade and abrasion resistant textured polyester powder coat finish with 3.0 mil nominal thickness. Finish tested to withstand 5000 hours in salt spray exposure per ASTM B117 and Coastal Finish per ASTM G85. Finish tested 500 hours in UV exposure per ASTM G154 and meets ASTM D523 gloss retention.

Listings/Ratings/Labels

Luminaires are UL listed for use in wet locations in the United States and Canada and are rated IP66. Luminaires are qualified to operate at ambient temperatures of -40°C to 50°C. (-40°F to 122°F)

Government Procurement Compliance

BAA - Buy America(n) Act: All LEOTEK luminaires qualify as a "Domestic End Product" per the Buy American Act as governed by FAR.

BABA - Build America Buy America: All LEOTEK luminaires are compliant with the requirements for BABA as outlined per the Federal Highway Administration (FHWA).

Quality Control

Every luminaire is assembled in the USA and is performance tested before and after a 2-hour burn-in period.

Warranty

10-year limited warranty is standard on luminaire and components. 5-year limited warranty on luminaires and components with a motion sensor. See LEOTEK.com for warranty details, terms and conditions.

Standards

Luminaire complies with:

ANSI: C136.2, C136.3, C136.10, C136.13, C136.15, C136.22, C136.31, C136.35, C136.37, C136.41, C62.41, C78.377, C82.77

Other: FCC 47 CFR, IEC 60598, ROHS II, UL 1449, UL 1598

Performance Data* (70CRI*, 25°C ambient...*for 80CRI option use a 0.91 multiplier)

Normal tolerance +/- 10% due to factors that include distribution type, LED bin variance and ambient temperatures.

Perf. Code	System Wattage (W)	Optic	27K7 (2700K CCT, 70CRI)					30K7 (3000K CCT, 70CRI)					40K7 (4000K CCT, 70CRI)					50K7 (5000K CCT, 70CRI)					LLD @ 25°C		
			Lumens	LPW	B	U	G	Lumens	LPW	B	U	G	Lumens	LPW	B	U	G	Lumens	LPW	B	U	G	50K Hours	75K Hours	100K Hours
P1	57 27K7, 30K7	NR	9,411	165.1	2	0	2	10,071	176.7	2	0	2	11,164	189.2	2	0	2	11,164	189.2	2	0	2	0.979	0.972	0.965
		MR	9,125	160.1	2	0	2	9,765	171.3	2	0	2	10,825	183.5	2	0	2	10,825	183.5	2	0	2			
		WR	9,361	164.2	2	0	2	10,017	175.7	2	0	2	11,104	188.2	3	0	3	11,104	188.2	3	0	3			
		T2R	9,361	164.2	2	0	2	10,017	175.7	2	0	2	11,104	188.2	3	0	3	11,104	188.2	3	0	3			
		T2F	9,089	159.5	2	0	2	9,726	170.6	2	0	2	10,782	182.7	2	0	2	10,782	182.7	2	0	2			
	59 40K7, 50K7	T3R	9,388	164.7	2	0	2	10,046	176.2	2	0	2	11,137	188.8	2	0	2	11,137	188.8	2	0	2			
		T3F	9,122	160.0	2	0	2	9,761	171.2	2	0	2	10,821	183.4	2	0	2	10,821	183.4	2	0	2			
		T4R	8,878	155.8	2	0	2	9,501	166.7	2	0	2	10,532	178.5	2	0	2	10,532	178.5	2	0	2			
		T4F	9,058	158.9	2	0	3	9,693	170.1	2	0	3	10,745	182.1	2	0	3	10,745	182.1	2	0	3			
		T5	9,273	162.7	4	0	2	9,923	174.1	4	0	2	11,000	186.4	4	0	2	11,000	186.4	4	0	2			
P2	59 27K7, 30K7	NR	9,968	168.9	2	0	2	10,667	180.8	2	0	2	14,325	186.0	3	0	2	14,325	186.0	3	0	2	0.979	0.972	0.965
		MR	9,666	163.8	2	0	2	10,343	175.3	2	0	2	13,889	180.4	3	0	3	13,889	180.4	3	0	3			
		WR	9,915	168.1	2	0	2	10,610	179.8	2	0	2	14,248	185.0	3	0	3	14,248	185.0	3	0	3			
		T2R	9,915	168.1	2	0	2	10,610	179.8	2	0	2	14,248	185.0	3	0	3	14,248	185.0	3	0	3			
		T2F	9,627	163.2	2	0	2	10,302	174.6	2	0	2	13,834	179.7	3	0	3	13,834	179.7	3	0	3			
	77 40K7, 50K7	T3R	9,944	168.5	2	0	2	10,641	180.4	2	0	2	14,289	185.6	3	0	3	14,289	185.6	3	0	3			
		T3F	9,662	163.8	2	0	2	10,339	175.2	2	0	2	13,884	180.3	3	0	3	13,884	180.3	3	0	3			
		T4R	9,404	159.4	2	0	2	10,063	170.6	2	0	2	13,513	175.5	2	0	2	13,513	175.5	2	0	2			
		T4F	9,594	162.6	2	0	3	10,267	174.0	2	0	3	13,786	179.0	2	0	3	13,786	179.0	2	0	3			
		T5	9,822	166.5	4	0	2	10,511	178.2	4	0	2	14,114	183.3	4	0	3	14,114	183.3	4	0	3			
P3	77 27K7, 30K7	NR	12,791	166.1	3	0	2	13,688	177.8	3	0	2	17,483	186.0	3	0	2	17,483	186.0	3	0	2	0.979	0.972	0.965
		MR	12,401	161.1	3	0	3	13,271	172.4	3	0	3	16,951	180.3	3	0	3	16,951	180.3	3	0	3			
		WR	12,722	165.2	3	0	3	13,614	176.8	3	0	3	17,389	185.0	3	0	3	17,389	185.0	3	0	3			
		T2R	12,722	165.2	3	0	3	13,614	176.8	3	0	3	17,389	185.0	3	0	3	17,389	185.0	3	0	3			
		T2F	12,352	160.4	3	0	3	13,218	171.7	3	0	3	16,883	179.6	3	0	3	16,883	179.6	3	0	3			
	94 40K7, 50K7	T3R	12,759	165.7	2	0	2	13,653	177.3	3	0	3	17,439	185.5	3	0	3	17,439	185.5	3	0	3			
		T3F	12,397	161.0	2	0	2	13,266	172.3	3	0	3	16,945	180.3	3	0	3	16,945	180.3	3	0	3			
		T4R	12,066	156.7	2	0	2	12,912	167.7	2	0	2	16,492	175.4	2	0	3	16,492	175.4	2	0	3			
		T4F	12,310	159.9	2	0	3	13,173	171.1	2	0	3	16,826	179.0	3	0	3	16,826	179.0	3	0	3			
		T5	12,602	163.7	4	0	3	13,486	175.1	4	0	3	17,225	183.2	5	0	3	17,225	183.2	5	0	3			
P4	94 27K7, 30K7	NR	15,611	166.1	3	0	2	16,705	177.7	3	0	2	20,771	187.1	3	0	2	20,771	187.1	3	0	2	0.979	0.972	0.965
		MR	15,136	161.0	3	0	3	16,197	172.3	3	0	3	20,140	181.4	3	0	3	20,140	181.4	3	0	3			
		WR	15,527	165.2	3	0	3	16,615	176.8	3	0	3	20,660	186.1	3	0	3	20,660	186.1	3	0	3			
		T2R	15,527	165.2	3	0	3	16,615	176.8	3	0	3	20,660	186.1	3	0	3	20,660	186.1	3	0	3			
		T2F	15,075	160.4	3	0	3	16,132	171.6	3	0	3	20,059	180.7	3	0	3	20,059	180.7	3	0	3			
	111 40K7, 50K7	T3R	15,571	165.6	3	0	3	16,663	177.3	3	0	3	20,719	186.7	3	0	3	20,719	186.7	3	0	3			
		T3F	15,130	161.0	3	0	3	16,191	172.2	3	0	3	20,132	181.4	3	0	3	20,132	181.4	3	0	3			
		T4R	14,726	156.7	2	0	2	15,758	167.6	2	0	3	19,594	176.5	3	0	3	19,594	176.5	3	0	3			
		T4F	15,024	159.8	3	0	3	16,077	171.0	3	0	3	19,991	180.1	3	0	4	19,991	180.1	3	0	4			
		T5	15,380	163.6	4	0	3	16,458	175.1	4	0	3	20,465	184.4	5	0	3	20,465	184.4	5	0	3			
P5	111 27K7, 30K7	NR	18,546	167.1	3	0	2	19,847	178.8	3	0	2	23,816	189.0	3	0	3	23,816	189.0	3	0	3	0.979	0.972	0.965
		MR	17,983	162.0	3	0	3	19,244	173.4	3	0	3	23,092	183.3	3	0	3	23,092	183.3	3	0	3			
		WR	18,447	166.2	3	0	3	19,741	177.8	3	0	3	23,688	188.0	3	0	3	23,688	188.0	3	0	3			
		T2R	18,447	166.2	3	0	3	19,741	177.8	3	0	3	23,688	188.0	3	0	3	23,688	188.0	3	0	3			
		T2F	17,911	161.4	3	0	3	19,166	172.7	3	0	3	23,000	182.5	3	0	3	23,000	182.5	3	0	3			
	126 40K7, 50K7	T3R	18,500	166.7	3	0	3	19,797	178.4	3	0	3	23,756	188.5	3	0	3	23,756	188.5	3	0	3			
		T3F	17,976	161.9	3	0	3	19,236	173.3	3	0	3	23,083	183.2	3	0	3	23,083	183.2	3	0	3			
		T4R	17,495	157.6	2	0	3	18,722	168.7	3	0	3	22,466	178.3	3	0	3	22,466	178.3	3	0	3			
		T4F	17,850	160.8	3	0	3	19,101	172.1	3	0	3	22,921	181.9	3	0	4	22,921	181.9	3	0	4			
		T5	18,273	164.6	5	0	3	19,554	176.2	5	0	3	23,465	186.2	5	0	3	23,465	186.2	5	0	3			
P6	126 27K7, 30K7	NR	21,265	168.8	3	0	2	22,756	180.6	3	0	2	26,791	187.3	3	0	3	26,791	187.3	3	0	3	0.979	0.972	0.965
		MR	20,619	163.6	3	0	3	22,064	175.1	3	0	3	25,976	181.7	3	0	3	25,976	181.7	3	0	3			
		WR	21,151	167.9	3	0	3	22,634	179.6	3	0	3	26,647	186.3	3	0	3	26,647	186.3	3	0	3			
		T2R	21,151	167.9	3	0	3	22,634	179.6	3	0	3	26,647	186.3	3	0	3	26,647	186.3	3	0	3			
		T2F	20,537	163.0	3	0	3	21,977	174.4	3	0	3	25,873	180.9	3	0	3	25,873	180.9	3	0	3			
	143 40K7, 50K7	T3R	21,212	168.3	3	0	3	22,699	180.2	3	0	3	26,724	186.9	3	0	4	26,724	186.9	3	0	4			
		T3F	20,611	163.6	3	0	3	22,056	175.0	3	0	3	25,967	181.6	3	0	3	25,967	181.6	3	0	3			
		T4R	20,060	159.2	3	0	3	21,466	170.4	3	0	3	25,273	176.7	3	0	4	25,273	176.7	3	0	4			
		T4F	20,466	162.4	3	0	4	21,901	173.8	3															

Performance Data* (70CRI*, 25°C ambient...*for 80CRI option use a 0.91 multiplier)

Normal tolerance +/- 10% due to factors that include distribution type, LED bin variance and ambient temperatures.

Perf. Code	System Wattage (W)	Optic	27K7 (2700K CCT, 70CRI)					30K7 (3000K CCT, 70CRI)					40K7 (4000K CCT, 70CRI)					50K7 (5000K CCT, 70CRI)					LLD @ 25°C		
			Lumens	LPW	B	U	G	Lumens	LPW	B	U	G	Lumens	LPW	B	U	G	Lumens	LPW	B	U	G	50K Hours	75K Hours	100K Hours
P8	160 27K7, 30K7	NR	26,516	165.7	3	0	3	28,375	177.3	4	0	3	32,532	182.8	4	0	3	32,532	182.8	4	0	3	0.942	0.919	0.896
		MR	25,709	160.7	3	0	3	27,512	172.0	3	0	3	31,543	177.2	4	0	4	31,543	177.2	4	0	4			
		WR	26,374	164.8	3	0	3	28,223	176.4	4	0	4	32,357	181.8	4	0	4	32,357	181.8	4	0	4			
		T2R	26,374	164.8	3	0	3	28,223	176.4	4	0	4	32,357	181.8	4	0	4	32,357	181.8	4	0	4			
		T2F	25,607	160.0	3	0	3	27,403	171.3	3	0	3	31,417	176.5	4	0	4	31,417	176.5	4	0	4			
	178 40K7, 50K7	T3R	26,449	165.3	3	0	4	28,304	176.9	3	0	4	32,451	182.3	3	0	4	32,451	182.3	3	0	4			
		T3F	25,700	160.6	3	0	3	27,502	171.9	3	0	3	31,531	177.1	3	0	3	31,531	177.1	3	0	3			
		T4R	25,014	156.3	3	0	4	26,767	167.3	3	0	4	30,688	172.4	3	0	4	30,688	172.4	3	0	4			
		T4F	25,520	159.5	3	0	4	27,309	170.7	3	0	4	31,310	175.9	3	0	5	31,310	175.9	3	0	5			
		T5	26,125	163.3	5	0	4	27,957	174.7	5	0	4	32,053	180.1	5	0	4	32,053	180.1	5	0	4			
P9	178 27K7, 30K7	NR	29,048	163.2	4	0	3	31,084	174.6	4	0	3	35,273	173.8	4	0	4	35,273	173.8	4	0	4	0.942	0.919	0.896
		MR	28,165	158.2	3	0	3	30,139	169.3	3	0	3	34,200	168.5	4	0	4	34,200	168.5	4	0	4			
		WR	28,892	162.3	4	0	4	30,917	173.7	4	0	4	35,083	172.8	4	0	4	35,083	172.8	4	0	4			
		T2R	28,892	162.3	4	0	4	30,917	173.7	4	0	4	35,083	172.8	4	0	4	35,083	172.8	4	0	4			
		T2F	28,052	157.6	4	0	4	30,019	168.6	4	0	4	34,064	167.8	4	0	4	34,064	167.8	4	0	4			
	203 40K7, 50K7	T3R	28,975	162.8	3	0	4	31,007	174.2	3	0	4	35,185	173.3	4	0	4	35,185	173.3	4	0	4			
		T3F	28,154	158.2	3	0	3	30,128	169.3	3	0	3	34,188	168.4	4	0	4	34,188	168.4	4	0	4			
		T4R	27,401	153.9	3	0	4	29,322	164.7	3	0	4	33,274	163.9	3	0	4	33,274	163.9	3	0	4			
		T4F	27,957	157.1	3	0	4	29,917	168.1	3	0	5	33,948	167.2	3	0	5	33,948	167.2	3	0	5			
		T5	28,620	160.8	5	0	4	30,627	172.1	5	0	4	34,753	171.2	5	0	4	34,753	171.2	5	0	4			
P10	203 27K7, 30K7	NR	31,495	155.1	4	0	3	33,703	166.0	4	0	3	38,113	174.0	4	0	4	38,113	174.0	4	0	4	0.942	0.919	0.896
		MR	30,537	150.4	3	0	3	32,678	161.0	4	0	4	36,953	168.7	4	0	4	36,953	168.7	4	0	4			
		WR	31,326	154.3	4	0	4	33,522	165.1	4	0	4	37,908	173.1	4	0	4	37,908	173.1	4	0	4			
		T2R	31,326	154.3	4	0	4	33,522	165.1	4	0	4	37,908	173.1	4	0	4	37,908	173.1	4	0	4			
		T2F	30,416	149.8	4	0	4	32,548	160.3	4	0	4	36,806	168.1	4	0	4	36,806	168.1	4	0	4			
	219 40K7, 50K7	T3R	31,417	154.8	3	0	4	33,619	165.6	3	0	4	38,017	173.6	4	0	4	38,017	173.6	4	0	4			
		T3F	30,526	150.4	3	0	3	32,667	160.9	4	0	4	36,940	168.7	4	0	4	36,940	168.7	4	0	4			
		T4R	29,710	146.4	3	0	4	31,793	156.6	3	0	4	35,953	164.2	3	0	4	35,953	164.2	3	0	4			
		T4F	30,312	149.3	3	0	5	32,437	159.8	3	0	5	36,680	167.5	4	0	5	36,680	167.5	4	0	5			
		T5	31,031	152.9	5	0	4	33,206	163.6	5	0	4	37,551	171.5	5	0	4	37,551	171.5	5	0	4			
P11	219 27K7, 30K7	NR	34,031	155.4	4	0	3	36,417	166.3	4	0	4	42,274	174.7	4	0	4	42,274	174.7	4	0	4	0.942	0.919	0.896
		MR	32,995	150.7	4	0	4	35,309	161.2	4	0	4	40,988	169.4	4	0	4	40,988	169.4	4	0	4			
		WR	33,848	154.6	4	0	4	36,221	165.4	4	0	4	42,047	173.7	4	0	4	42,047	173.7	4	0	4			
		T2R	33,848	154.6	4	0	4	36,221	165.4	4	0	4	42,047	173.7	4	0	4	42,047	173.7	4	0	4			
		T2F	32,864	150.1	4	0	4	35,168	160.6	4	0	4	40,825	168.7	4	0	4	40,825	168.7	4	0	4			
	242 40K7, 50K7	T3R	33,945	155.0	4	0	4	36,325	165.9	4	0	4	42,168	174.2	4	0	5	42,168	174.2	4	0	5			
		T3F	32,984	150.6	4	0	4	35,296	161.2	4	0	4	40,973	169.3	4	0	4	40,973	169.3	4	0	4			
		T4R	32,102	146.6	3	0	4	34,353	156.9	3	0	4	39,878	164.8	3	0	5	39,878	164.8	3	0	5			
		T4F	32,752	149.6	3	0	5	35,048	160.0	4	0	5	40,685	168.1	4	0	5	40,685	168.1	4	0	5			
		T5	33,529	153.1	5	0	4	35,880	163.8	5	0	4	41,651	172.1	5	0	5	41,651	172.1	5	0	5			
P12	242 27K7, 30K7	NR	37,746	156.0	4	0	4	40,393	166.9	4	0	4	44,983	173.0	4	0	4	44,983	173.0	4	0	4	0.942	0.919	0.896
		MR	36,598	151.2	4	0	4	39,164	161.8	4	0	4	43,615	167.8	4	0	4	43,615	167.8	4	0	4			
		WR	37,544	155.1	4	0	4	40,176	166.0	4	0	4	44,741	172.1	4	0	4	44,741	172.1	4	0	4			
		T2R	37,544	155.1	4	0	4	40,176	166.0	4	0	4	44,741	172.1	4	0	4	44,741	172.1	4	0	4			
		T2F	36,453	150.6	4	0	4	39,008	161.2	4	0	4	43,441	167.1	4	0	5	43,441	167.1	4	0	5			
	260 40K7, 50K7	T3R	37,652	155.6	4	0	4	40,292	166.5	4	0	5	44,870	172.6	4	0	5	44,870	172.6	4	0	5			
		T3F	36,585	151.2	4	0	4	39,150	161.8	4	0	4	43,599	167.7	4	0	4	43,599	167.7	4	0	4			
		T4R	35,607	147.1	3	0	4	38,103	157.5	3	0	5	42,433	163.2	4	0	5	42,433	163.2	4	0	5			
		T4F	36,328	150.1	4	0	5	38,875	160.6	4	0	5	43,293	166.5	4	0	5	43,293	166.5	4	0	5			
		T5	37,190	153.7	5	0	4	39,798	164.5	5	0	4	44,320	170.5	5	0	5	44,320	170.5	5	0	5			
P13	260 27K7, 30K7	NR	40,165	154.5	4	0	4	42,981	165.3	4	0	4	47,639	170.7	4	0	4	47,639	170.7	4	0	4	0.942	0.919	0.896
		MR	38,944	149.8	4	0	4	41,674	160.3	4	0	4	46,190	165.6	4	0	4	46,190	165.6	4	0	4			
		WR	39,949	153.7	4	0	4	42,750	164.4	4	0	4	47,383	169.8	4	0	4	47,383	169.8	4	0	4			
		T2R	39,949	153.7	4	0	4	42,750	164.4	4	0	4	47,383	169.8	4	0	4	47,383	169.8	4	0	4			
		T2F	38,788	149.2	4	0	4	41,508	159.6	4	0	4	46,006	164.9	4	0	5	46,006	164.9	4	0	5			
	279 40K7, 50K7	T3R	40,064	154.1	4	0	5	42,873	164.9	4	0	5	47,520	170.3	4	0	5	47,520	170.3	4	0	5			
		T3F	38,930	149.7	4	0	4	41,659	160.2	4	0	4	46,174	165.5	4	0	4	46,174	165.5	4	0	4			
		T4R	37,888	145.7	3	0	5	40,545	155.9	3	0	5	44,939	161.1	4	0	5	44,939	161.1	4	0	5			
		T4F	38,656	148.7	4	0																			

Optional Field Adjustable Performance Selector 'PS' (*'PS' is only compatible with standard 0-10V drivers, not compatible w/ optional DALI drivers*)

The optional Performance Selector is an integral dial that allows for field adjustable lumen/wattage dimming control for added design versatility. Normal tolerance +/- 8%.

2700K, 3000K *

PS Position	Lumen Output %	P1	P2	P3	P4	P5	P6	P7	P8	P9	P10	P11	P12	P13	P14
		Wattage (W)													
8	100%	57	59	77	94	111	126	143	160	178	203	219	242	260	279
7	90%	50	52	68	83	98	112	127	142	158	180	194	214	230	247
6	80%	45	47	61	75	88	100	114	127	142	161	174	192	207	222
5	70%	39	41	53	65	76	87	98	110	122	140	151	166	179	192
4	60%	34	35	46	56	67	76	86	96	107	122	132	145	156	168
3	50%	28	29	38	47	55	62	71	79	88	100	108	120	129	138
2	40%	22	23	30	37	44	50	56	63	70	80	86	95	102	110
1	30%	17	17	23	28	33	37	42	47	53	60	65	71	77	82

*For 80CRI option use an additional 0.91 lumen multiplier.

4000K, 5000K *

PS Position	Lumen Output %	P1	P2	P3	P4	P5	P6	P7	P8	P9	P10	P11	P12	P13	P14
		Wattage (W)													
8	100%	59	77	94	111	126	143	160	178	203	219	242	260	279	307
7	90%	52	68	83	98	112	127	142	158	180	194	214	230	247	272
6	80%	47	61	75	88	100	114	127	142	161	174	192	207	222	244
5	70%	41	53	65	76	87	98	110	122	140	151	166	179	192	211
4	60%	35	46	56	67	76	86	96	107	122	132	145	156	168	185
3	50%	29	38	47	55	62	71	79	88	100	108	120	129	138	152
2	40%	23	30	37	44	50	56	63	70	80	86	95	102	110	121
1	30%	17	23	28	33	37	42	47	53	60	65	71	77	82	91

*For 80CRI option use an additional 0.91 lumen multiplier.

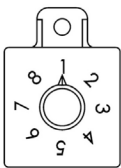

Optional Field Adjustable Performance Selector 'PS' Dial

IES TM-21 LED Lumen Maintenance (**values italicized are per LM-80 data that is extrapolated beyond the TM-21 6X standard*)

Reported lumen maintenance life projections are based on 6X the duration of the LED's IES LM-80 tested performance data in accordance per IES TM-21 guidelines.

Performance Code P1 to P7	IES TM-21 LED Lumen Maintenance					
	0 Hrs	25,000 Hrs	50,000 Hrs	60,000 Hrs	*75,000 Hrs	*100,000 Hrs
VTM @ 25°C Ambient	100.00%	98.60%	97.89%	97.61%	<i>97.19%</i>	<i>96.49%</i>
VTM @ 50°C Ambient	100.00%	96.18%	93.41%	92.32%	<i>90.71%</i>	<i>88.10%</i>

Performance Code P8 to P14	IES TM-21 LED Lumen Maintenance					
	0 Hrs	25,000 Hrs	50,000 Hrs	60,000 Hrs	*75,000 Hrs	*100,000 Hrs
VTM @ 25°C Ambient	100.00%	96.65%	94.23%	93.27%	<i>91.86%</i>	<i>89.56%</i>
VTM @ 50°C Ambient	100.00%	94.89%	91.53%	90.22%	<i>88.29%</i>	<i>85.16%</i>

Optical Isofootcandle Plots ('P12' Performance Code, 4000K/5000K, 70CRI, 20' Mounting Height MH, Grid Scale = MH or 40' as shown)

Complete non-shielded & shielded photometric IES files are available for download at www.LEOTEK.com or can be found in AGI32's Photometric Instabase.

LEGEND

- 0.1 Fc
- 0.2 Fc
- 0.5 Fc
- 1.0 Fc

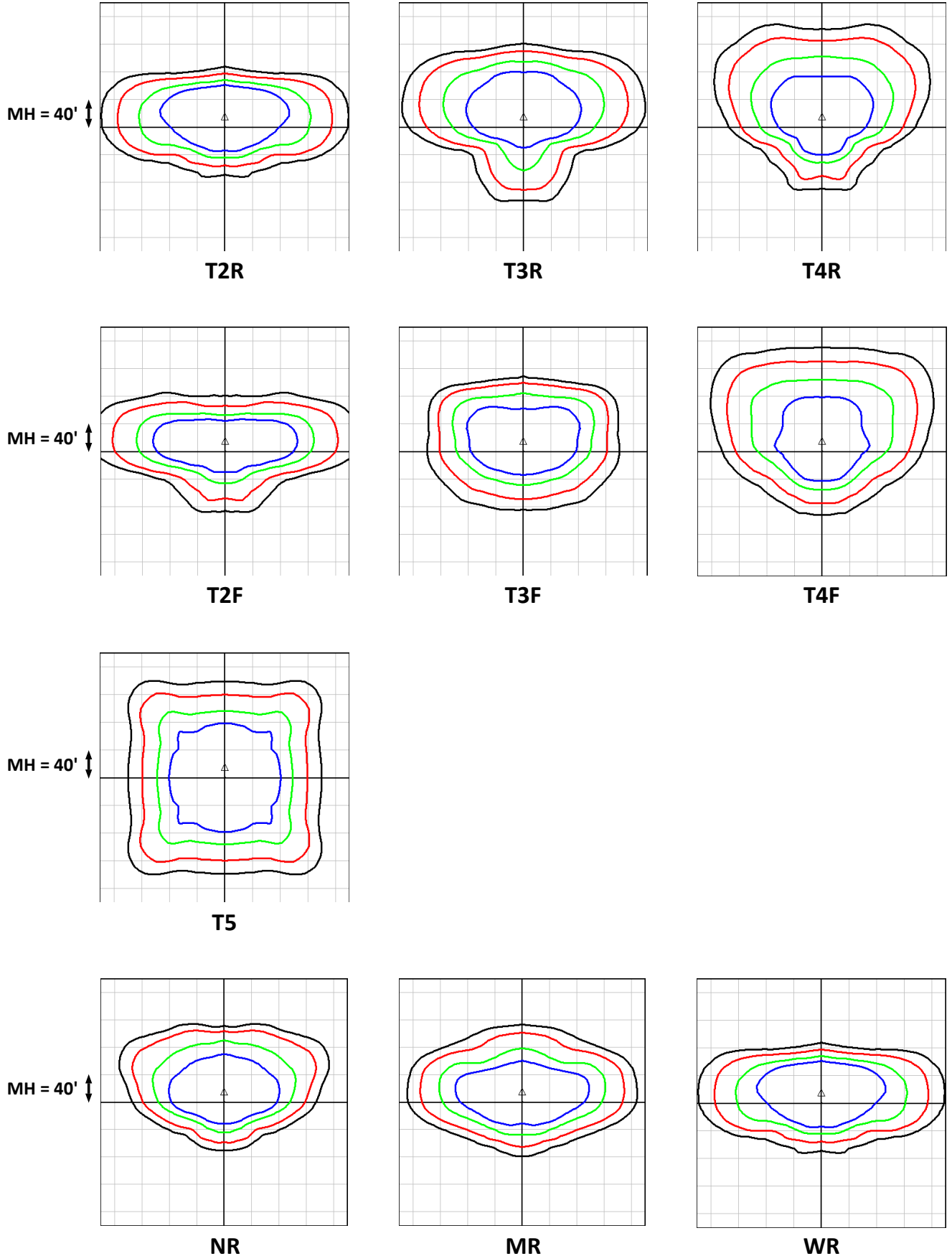

Mounting Option Details & Dimensional Information

'SF' Slipfitter Mount #1*

(available wire leads in UL splice compartment)
(shown w/ optional 'PCR7CR')

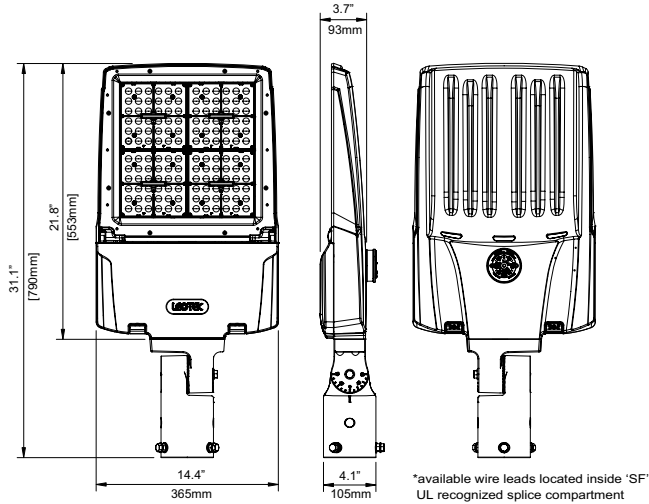

'SFC' Slipfitter #2*

(w/ 3-wire S/O Cord Center Fitter Exit)

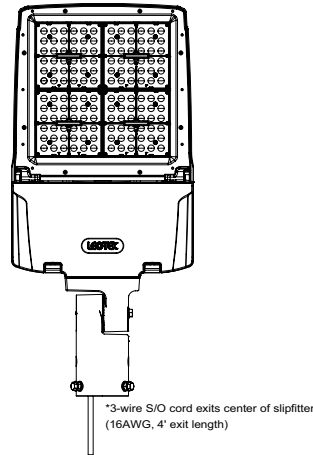

'SFH' Slipfitter #3*

(w/ 3-wire S/O Cord Bottom Housing Exit)

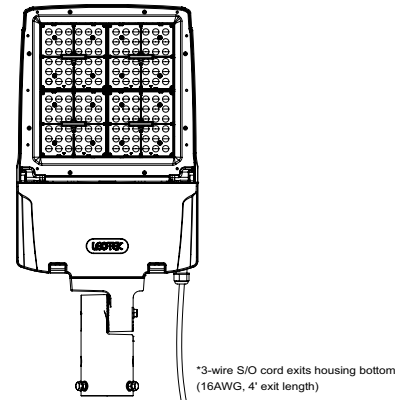

'SPM' Square & 'RPM' Round Pole Arm Mount*

(quick mount arm can retrofit up to 5.25" max. bolt spacing w/ no drilling required)

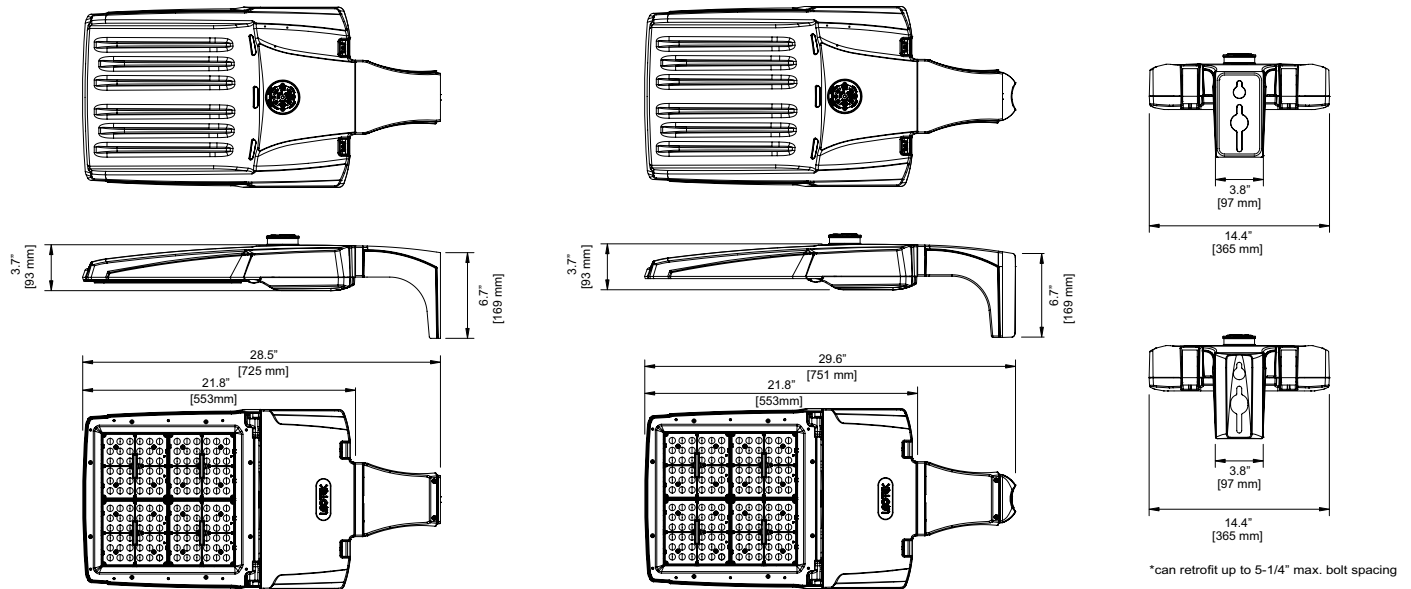

Mounting Option Details & Dimensional Information *(continued)*

'ASPM' Square & 'ARPM' Adjustable Round Pole Arm Mount*

(arm can retrofit up to 5.25" max. bolt spacing w/ no drilling required)

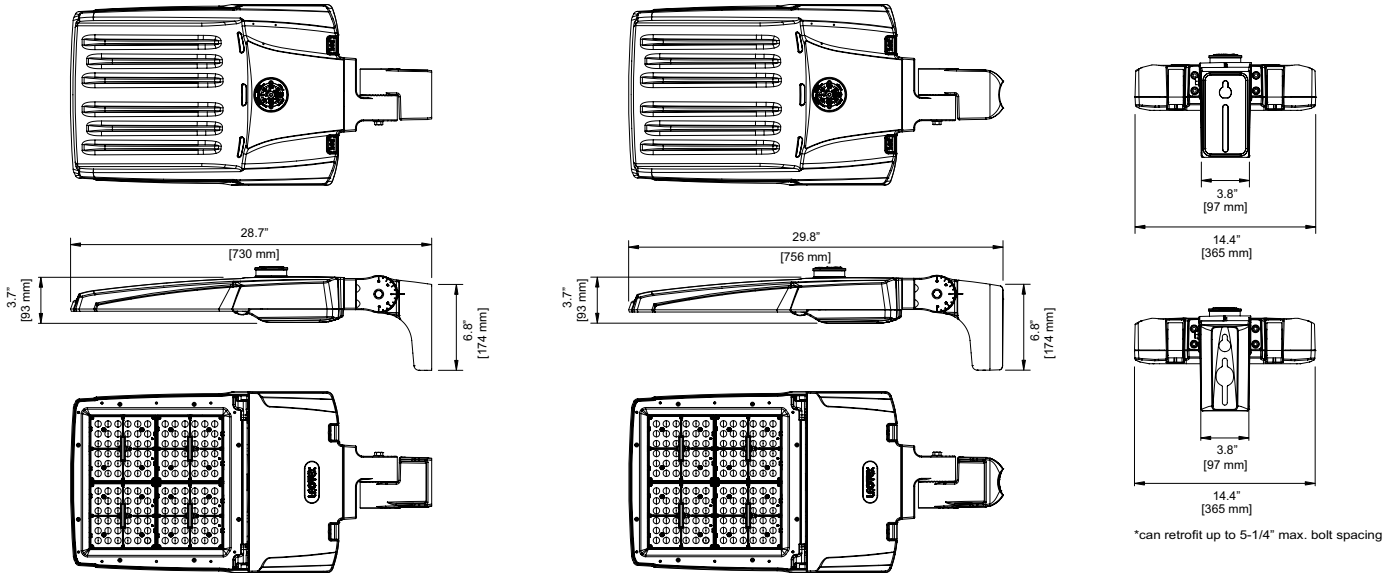

'MAF' Horizontal Mast Arm Fitter Mount*

(3/8" stainless steel thru-bolt & nut is included)

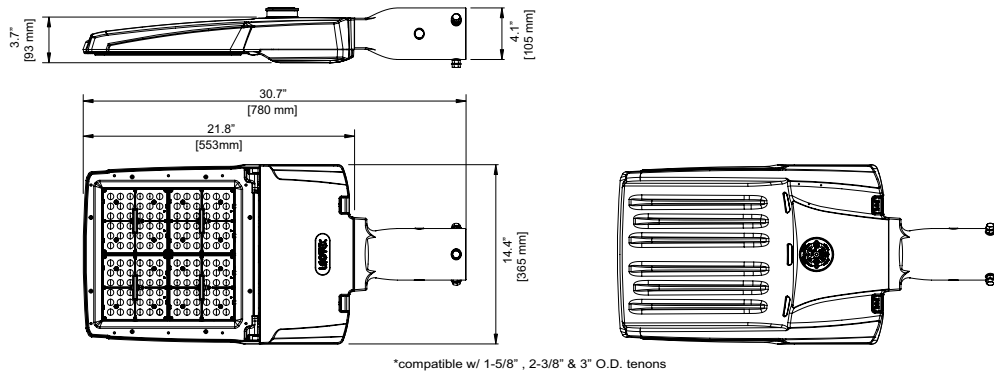

Key Additional Miscellaneous Product Features & Design Details

Integral Tool-Free Access Design

Tool-free electrical access & removable hinged door w/ fixed open door prop design for ease of installation or maintenance
(compatible w/ most lineman safety gloves)



Slipfitter w/ UL Splice Box

'SF' Slipfitter w/ integral UL recognized splice compartment
(w/ available wire lead access & WAGOs for ease of installation)



Self-Centering Design

Slipfitter & Mast Arm fitter options are designed with a self-centering & leveling design feature
(compatible w/ 1-5/8", 2-3/8" & 3" O.D. tenons)



3-Position Terminal Block 'TB' Option

For ease of maintenance & increased safety, improved wire management & robust product life cycle operation
(includes line, neutral & ground, accommodates 6 to 16AWG wire)

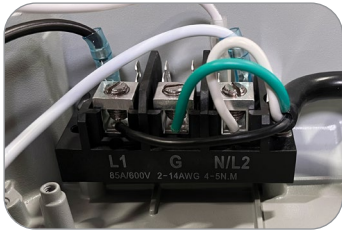

Performance Selector 'PS' Option

Allows for quick & easy field adjustment of wattage, lumen output and reduced SKU complexity
(fixed position dial ensures correct output setting)

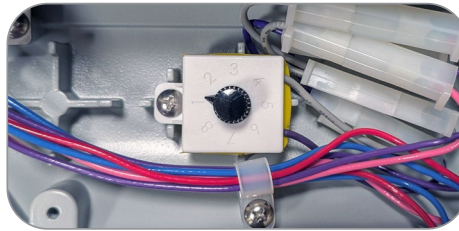

Integral VersaKick

VersaKick 'kickstand' props open the door during installation or maintenance
(allows for 'frustration free' ease of access)



Pass-Thru Convective Cooling

(3) integral cooling slots allows ambient air to flow freely thru the luminaire for enhanced thermal management
(maximizes lifetime of electrical components & lumen maintenance)



Tool-Free Removable Power Door Option 'PWRD'

All serviceable electrical components are mounted to a tool-free removable Power Door that can be removed in less than 15 seconds to safely service on the ground or replace in seconds
(undo MOLEX connectors, push two spring clips inward to unlock door, slide the door forward & lift to remove)

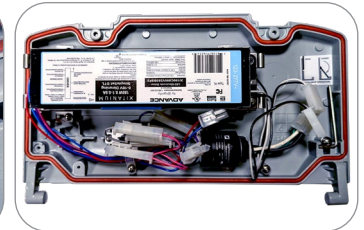
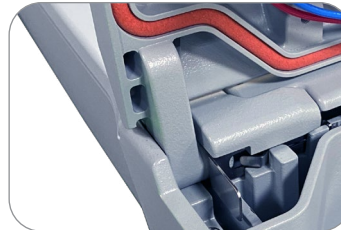
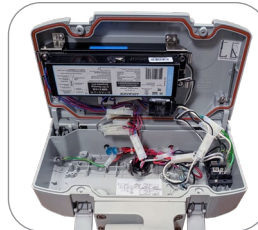

'4SS-VTM'
4-Sided Shield



'TBS-VTM'
Top or Bottom Shield



'LRS-VTM'
Left or Right Side Shield



'BDS-VTM'
Barn Door Shield



'WG-VTM'
Wire Guard



'VS-VTM'
Poly Vandal Shield

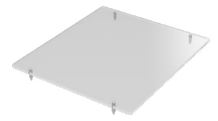

LEOLink ILS™ Intelligent Lighting System for Tomorrow's Smart & Sustainable Cities

Smart...Scalable...Effortless

LEOLink ILS is the next evolution in street lighting, integrating AI and IoT to transform a city's traditional outdoor lighting infrastructure into a smart, adaptive network. It empowers municipalities and utilities with real-time control, predictive maintenance, and rapid scalability, all with unmatched simplicity.

Integrating LEOTEK's AI-driven centralized management platform (LEOLink RenAI) with intelligent streetlight controllers, LEOLink ILS provides 24x7 visibility into the status and performance of streetlights enabling efficient energy use, real-time fault detection, and predictive maintenance across city-wide lighting networks. Easy "plug-and-play" deployment and scalability support users in achieving operational excellence, public safety, and long-term sustainability. With LEOLink ILS, cities are creating the backbone of a future-ready smart city.

Key Functions

Centralized, Remote Management

Gain complete control of your city's smart lighting infrastructure from a single, intuitive platform.

Instant Response to Anomalies

Automatically identify and respond to abnormal lighting behavior in real-time.

AI-Powered Predictive Maintenance

Detect and address faults before they occur, minimizing downtime and maintenance costs.

Actionable Insights Through Data Visualization

Monitor asset performance and energy trends with clear, interactive dashboards and reports.

Energy Efficiency & Cost Savings

Optimize energy usage with intelligent scheduling and dimming, reducing operational expenses.

LEOLink NB01 Plus Smart Controller Key Features & Benefits

The smartest fit for 7-PIN NEMA fixtures. Engineered to deliver seamless performance, trusted security, and plug-and-play simplicity, all in one powerful, next-generation controller.



*LEOLink 'NB01P' Smart Controller

Model	Form Factor	Fixture Compatibility	Connectivity	Power Source	Typical Use Case
NB01 Plus	NEMA 7-pin	Most ANSI C136.41-compliant fixtures	NB-IoT / LTE CAT-M	Powered via NEMA socket	Retrofit or upgrade existing fixtures



Self-Monitoring & Fault Detection

NB01P continuously monitors the luminaire's operational status, identifying power outages, failures, and abnormal energy patterns for fast diagnostics and improved maintenance efficiency.



AI-Driven Adaptive Dimming

Participates with LEOLink RenAI to enable intelligent dimming strategies, including human-centric lighting adjustments based on real-time traffic, weather, and pedestrian activity.



Ultra-High Connectivity

Dual-mode cellular communication using the world's most reliable and secure carriers ensures a 99.5% connection success rate, delivering reliable continuous data transmission even in challenging environments.



Predictive Maintenance & Analytics

Advanced failure analysis and predictive diagnostics move cities from reactive to preventative maintenance strategies that reduce downtime and operational costs.



Built-In Surge Protection

Advanced surge protection against lightning and voltage spikes safeguards critical streetlight infrastructure.

LEOLink RenAI Central Management System Key Features & Benefits

An AI-powered cloud-based streetlight Central Management System (CMS), LEOLink RenAI is at the core of the LEOLink Intelligent Lighting System (ILS). Unlike traditional CMS platforms, LEOLink RenAI, leverages a native AI foundation to transform streetlighting into a dynamic, adaptive, and self-optimizing system by analyzing real-time and historical data. Designed to meet the complex demands of modern roadway infrastructure, LEOLink RenAI helps municipalities improve energy efficiency, reduce operational costs, and improve public safety across city-wide lighting networks.



LiSA (LEOTEK intelligent Service Advisor)

LiSA, our AI-powered assistant, is available 24/7 to streamline operations, quickly answering questions, generating charts and tables, and assisting with troubleshooting to lighten your team's workload.



Fault Detection & Notification

Monitor streetlight health and status in real time to detect and receive instant fault alerts.



Asset Management

Collect and track roadway infrastructure asset information such as streetlight fixtures, poles and controllers. to drive operational efficiencies across from field maintenance to life cycle management.



Energy Consumption Management

Track usage, identify trends, and forecast energy needs for optimal efficiency.



Remote Control

Remotely switch lights ON/OFF and adjust brightness via an intuitive user interface.



Data Analysis & Reporting

Access historical insights, visualize data, and generate reports for informed decision-making.



Scheduled Dimming

Automatically adjusts brightness levels based on ambient light and pre-set schedules.

Motion Sensor (Optional) Specifications*

Integral motion sensor options are available for horizontal site & area and fixed wall mounting options only.

'MSL3', 'MSL7' motion sensors require secondary controls for ON/OFF capability (*ex. time clock or 0-10V by others*). Contact factory for Motion Sensor availability w/ 'PCR7CR' control ready receptacle for use with wireless 7-PIN control node (*by others*).

'MSL3P', 'MSL7P' motion sensors, luminaire includes a PCR7 photocontrol receptacle for use with a twist lock photocontrol for ON/OFF capability.
(*for use with our 'LLPC' or photocontrol by others, PINs 6 & 7 are not wired for controls, not compatible w/ wireless nodes.*)

Description

Digital passive infrared luminaire integrated outdoor occupancy sensor provides high/low/off control based on motion detection. Initial setup and subsequent sensor adjustments are made using a handheld configuration tool. PCR option is required for On/Off control using light detection. Available with both MV or HV input voltage options.

Operation

Standard factory setting will dim the luminaire to 50% until motion is sensed and then it will power to 100%. When motion is not detected for five minutes, the luminaire will dim back to 50%. Ramp up and fade down times are adjustable, but initially set to NONE. The percent dimming and time durations may be field adjusted as required using FSIR-100 configuration tool. FSIR-100 user guide available at: www.wattstopper.com.

Optical System

Multi-cell, multi-tier Fresnel lens with a 360 degree view detects unobstructed motion within one mounting height, up to 20 ft. maximum (MSL3) or 40 ft. maximum (MSL7). Consult factory for higher mounting height requirements.

Finish

Sensor exterior ring and lens are white polycarbonate, UV and impact resistant.

Listings/Ratings

Sensor is TUV, UL and cUL listed, IP66 rated and CE compliant.

Warranty

5-year limited warranty on luminaires and components with a motion sensor.

Motion Sensor (Optional) Data

MSL3 Lens Dimensions

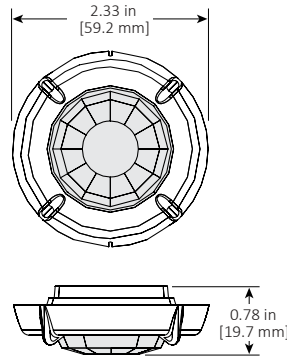

MSL3 Lens Coverage Top View

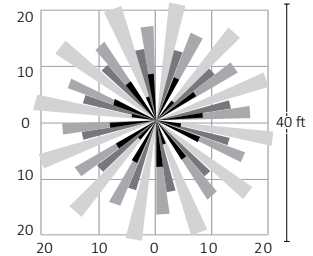

MSL3 Lens Coverage Side View

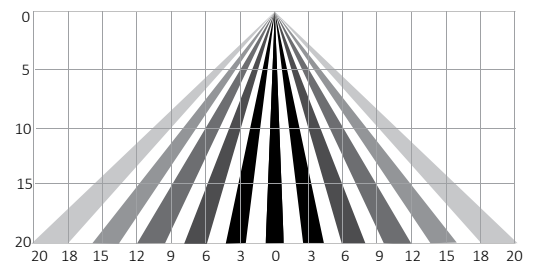

MSL7 Lens Dimensions

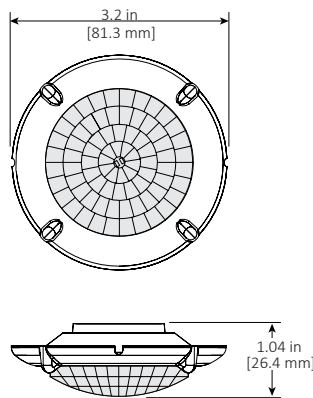

L7 Lens Coverage Top View

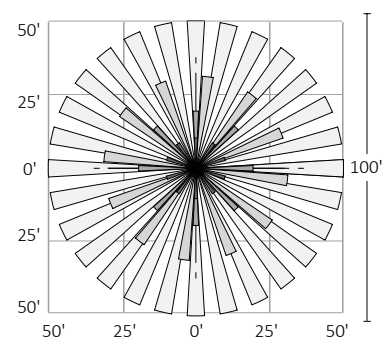

L7 Lens Coverage Side View

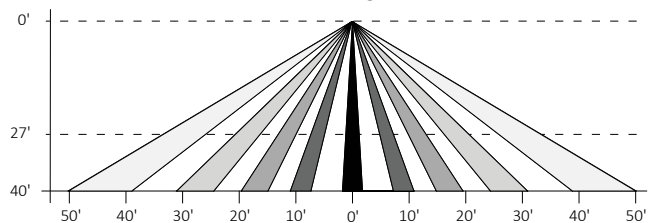

Part-Night Dimming Specifications

Description

Part-Night Dimming (PND) option enables significant energy savings by automatically dimming the luminaire during early morning hours when infrequent use is expected. Factory programmed dimming profiles automatically take into account seasonal changes based on geographical location by continuously monitoring the nighttime midpoint. PND does not provide power on/off control which is provided by external controls (example: time clock or a photocontrol using 'PCR7CR' option). Dimming profile of PND option is not field adjustable.

Operation

Based on the PND profile that is selected, the luminaire dims to the corresponding % power for the corresponding length of time (based on the nighttime mid-point) as shown below. Mid-point is continuously recalculated in the luminaire by monitoring the average length of time between when the light turns on (power on) and turns off (power off) over the previous two days. In effect, this functionality will take two days to initialize after installation before any dimming will occur. Power interruptions are ignored and do not affect the determination of mid-point. A motion sensor ('MSL3', 'MSL7' or 'MSL3P', 'MSL7P') can be used with PND to temporarily override the dimming profile when motion is detected. Three factory programmed PND profiles are available for selection:

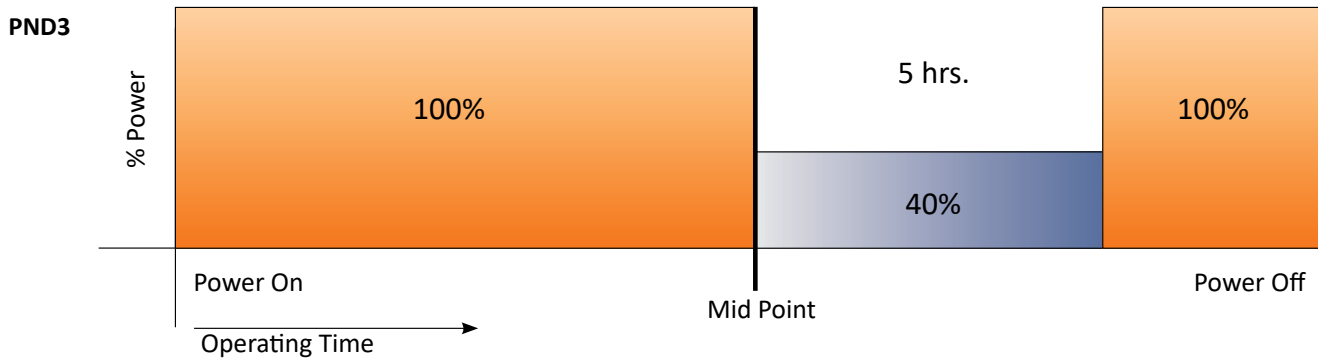
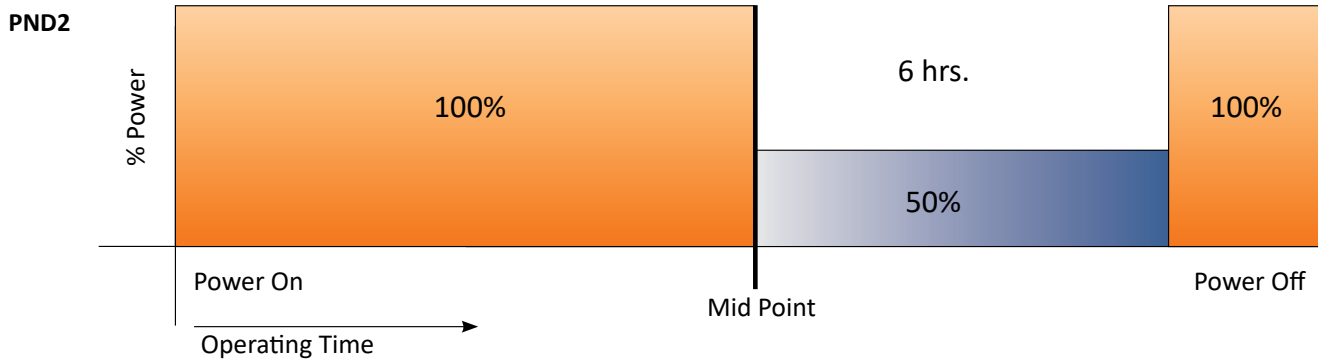
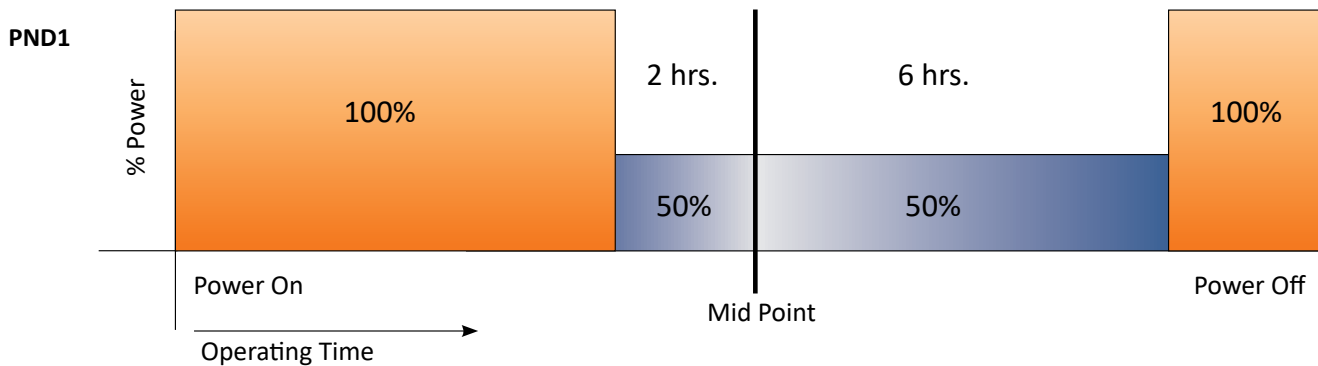

VersaTEK Medium LED OFF-Roadway - Luminaire EPA Values

(*Includes luminaire and mounting options shown. Secondary tenons, brackets or other accessories are not included in the EPA data.)

Luminaire Quantity & Orientation		Effective Projected Area (EPA ft ²)								
		Single	2 @ 90	2 @ 180	3 @ 90	3 @ 120	4 @ 90	2 Side by Side	3 Side by Side	4 Side by Side
Mounting Option	Tilt									
SF Slip Fitter	0°	0.99	1.43	1.97	2.42	2.11	2.42	0.89	1.34	1.78
	10°	0.99	1.61	1.97	2.59	2.46	2.59	1.25	1.87	2.50
	20°	1.03	2.02	1.97	3.00	3.19	3.00	2.06	3.09	4.13
	30°	1.42	2.41	1.97	3.39	3.94	3.39	2.84	4.26	5.69
SFC Slip Fitter Center	40°	1.78	2.76	1.97	3.75	4.64	3.75	3.55	5.33	7.10
	45°	1.94	2.92	1.97	3.91	4.96	3.91	3.87	5.81	7.75
	50°	2.08	3.07	2.08	4.05	5.25	4.05	4.16	6.24	8.32
	60°	2.33	3.31	2.33	4.30	5.74	4.30	4.66	6.99	9.32
SFH Slip Fitter Housing	70°	2.51	3.49	2.51	4.48	6.11	4.48	5.02	7.52	10.03
	80°	2.63	3.61	2.63	4.60	6.35	4.60	5.25	7.88	10.50
	90°	2.67	3.65	2.67	4.64	6.44	4.64	5.34	8.01	10.68
	0°	0.88	1.44	1.76	2.33	2.25	2.33	1.13	1.69	2.25
ASPM & ARPM Adjustable Square & Round Pole Arm Mount	10°	0.88	1.64	1.76	2.53	2.62	2.53	1.52	2.28	3.05
	20°	1.17	2.05	1.76	2.93	3.35	2.93	2.34	3.51	4.68
	30°	1.56	2.44	1.76	3.32	4.11	3.32	3.12	4.68	6.24
	40°	1.91	2.80	1.91	3.68	4.80	3.68	3.83	5.74	7.66
	45°	2.08	2.96	2.08	3.84	5.12	3.84	4.15	6.23	8.30
	50°	2.22	3.10	2.22	3.98	5.41	3.98	4.44	6.66	8.89
	60°	2.47	3.35	2.47	4.23	5.91	4.23	4.94	7.40	9.87
	70°	2.65	3.53	2.65	4.41	6.27	4.41	5.29	7.94	10.59
	80°	2.76	3.65	2.76	4.53	6.52	4.53	5.53	8.29	11.06
	90°	2.80	3.69	2.80	4.57	6.61	4.57	5.61	8.41	11.21

Luminaire Quantity & Orientation		Effective Projected Area (EPA ft ²)					
		Single	2 @ 90	2 @ 180	3 @ 90	3 @ 120	4 @ 90
Mounting Option	Tilt						
SPM & RPM Sq. & Rd. Pole Arm	0°	0.85	1.42	1.70	2.27	2.21	2.27
MAF Mast Arm Fitter	0°	0.97	1.42	1.94	2.39	2.11	2.39

Fixed & Adjustable Square & Round Pole Arm Mount Drilling Dimensions for New Construction

(for additional details, please consult online installation instructions)

